

Memorex

MVT2194

SERVICE MANUAL

COLOR TELEVISION/VIDEO CASSETTE RECORDER

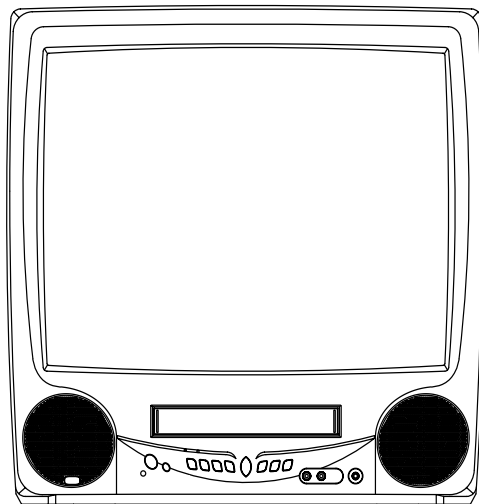

VHS

**ORIGINAL
MFR'S VERSION A**

SERVICING NOTICES ON CHECKING

1. KEEP THE NOTICES

As for the places which need special attentions, they are indicated with the labels or seals on the cabinet, chassis and parts. Make sure to keep the indications and notices in the operation manual.

2. AVOID AN ELECTRIC SHOCK

There is a high voltage part inside. Avoid an electric shock while the electric current is flowing.

3. USE THE DESIGNATED PARTS

The parts in this equipment have the specific characters of incombustibility and withstand voltage for safety. Therefore, the part which is replaced should be used the part which has the same character.

Especially as to the important parts for safety which is indicated in the circuit diagram or the table of parts as a  mark, the designated parts must be used.

4. PUT PARTS AND WIRES IN THE ORIGINAL POSITION AFTER ASSEMBLING OR WIRING

There are parts which use the insulation material such as a tube or tape for safety, or which are assembled in the condition that these do not contact with the printed board. The inside wiring is designed not to get closer to the pyrogenic parts and high voltage parts. Therefore, put these parts in the original positions.

5. TAKE CARE TO DEAL WITH THE CATHODE-RAY TUBE

In the condition that an explosion-proof cathode-ray tube is set in this equipment, safety is secured against implosion. However, when removing it or serving from backward, it is dangerous to give a shock. Take enough care to deal with it.

6. AVOID AN X-RAY

Safety is secured against an X-ray by considering about the cathode-ray tube and the high voltage peripheral circuit, etc.

Therefore, when repairing the high voltage peripheral circuit, use the designated parts and make sure not modify the circuit.

Repairing except indicates causes rising of high voltage, and it emits an X-ray from the cathode-ray tube.

7. PERFORM A SAFETY CHECK AFTER SERVICING

Confirm that the screws, parts and wiring which were removed in order to service are put in the original positions, or whether there are the portions which are deteriorated around the serviced places serviced or not. Check the insulation between the antenna terminal or external metal and the AC cord plug blades. And be sure the safety of that.

(INSULATION CHECK PROCEDURE)

1. Unplug the plug from the AC outlet.
2. Remove the antenna terminal on TV and turn on the TV.
3. Insulation resistance between the cord plug terminals and the eternal exposure metal **[Note 2]** should be more than 1M ohm by using the 500V insulation resistance meter **[Note 1]**.
4. If the insulation resistance is less than 1M ohm, the inspection repair should be required.

[Note 1]

If you have not the 500V insulation resistance meter, use a Tester.

[Note 2]

External exposure metal: Antenna terminal
Earphone jack

HOW TO ORDER PARTS

Please include the following informations when you order parts. (Particularly the VERSION LETTER.)

1. MODEL NUMBER and VERSION LETTER

The MODEL NUMBER can be found on the back of each product and the VERSION LETTER can be found at the end of the SERIAL NUMBER.

2. PART NO. and DESCRIPTION

You can find it in your SERVICE MANUAL.

TAPE REMOVAL METHOD AT NO POWER SUPPLY

1. Remove the VCR block from the main unit.
(Refer to item 1 of the DISASSEMBLY INSTRUCTIONS.)
2. Remove the screw ① of the Deck Chassis and remove the Loading Motor.
3. Rotate the Pinch Roller Cam in the direction of the arrow by hand to slacken the Video Tape.
4. Rotate the Clutch Ass'y either of the directions to wind the Video Tape in the Cassette Case.
5. Repeat the above step 3~4. Then take out the Video Cassette from the Deck Chassis. Be careful not to scratch on the tape.

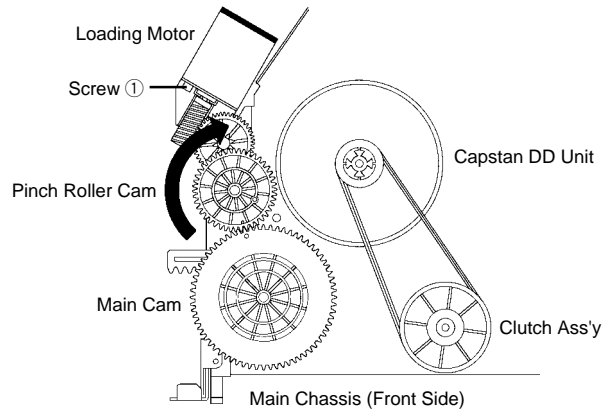

CONTENTS

SERVICING NOTICES ON CHECKING	A1-1
HOW TO ORDER PARTS	A1-1
TAPE REMOVAL METHOD AT NO POWER SUPPLY	A1-2
CONTENTS	A2-1
GENERAL SPECIFICATIONS	A3-1~A3-4
DISASSEMBLY INSTRUCTIONS	
1. REMOVAL OF MECHANICAL PARTS AND P. C. BOARDS	B1-1, B1-2
2. REMOVAL OF VCR DECK PARTS	B2-1~B2-6
3. REMOVAL OF ANODE CAP	B3-1
4. REMOVAL AND INSTALLATION OF FLAT PACKAGE IC	B4-1, B4-2
KEY TO ABBREVIATIONS	C1-1, C1-2
SERVICE MODE LIST	C2-1
PREVENTIVE CHECKS AND SERVICE INTERVALS	C3-1, C3-2
WHEN REPLACING EEPROM (MEMORY) IC	C4-1
SERVICING FIXTURES AND TOOLS	D1-1
PREPARATION FOR SERVICING	D1-1
MECHANICAL ADJUSTMENTS	D2-1~D2-4
ELECTRICAL ADJUSTMENTS	D3-1~D3-5
BLOCK DIAGRAMS	
TV	E-1, E-2
Y/C/AUDIO/HEAD AMP.	E-3, E-4
MICON/IN/OUT/AV	E-5, E-6
PRINTED CIRCUIT BOARDS	
SYSCON/CRT	F-1~ F-4
SCHEMATIC DIAGRAMS	
Y/C/AUDIO/HEAD AMP	G-1, G-2
MICON	G-3, G-4
IN/OUT	G-5, G-6
AV	G-7, G-8
CHROMA/IF	G-9, G-10
SOUND AMP	G-11, G-12
TV POWER	G-13, G-14
DEFLECTION	G-15, G-16
CRT	G-17, G-18
INTERCONNECTION DIAGRAM	G-19, G-20
WAVEFORMS	H-1, H-2
MECHANICAL EXPLODED VIEWS	I1-1, I1-2
CHASSIS EXPLODED VIEWS	I2-1, I2-2
MECHANICAL REPLACEMENT PARTS LIST	J1-1
CHASSIS REPLACEMENT PARTS LIST	J2-1
ELECTRICAL REPLACEMENT PARTS LIST	J3-1, J3-2

GENERAL SPECIFICATIONS

G-1	TV System	CRT	CRT Size / Visual Size	19 inch / 480.0mmV	
			CRT Type	Normal	
			Deflection	90 degree	
			Magnetic Field BV/BH	+0.45G / 0.18G	
			Color System	NTSC	
			Speaker	1 Speaker	
				Position	Front
				Size	3 Inch
				Impedance	8 ohm
			Sound Output	MAX	1.5 W
		10%(Typical)	1 W		
G-2	VCR System	System		VHS Player / Recorder	
		Video System		NTSC	
		Hi-Fi STEREO		No	
		NTSC PB		-	
		Deck	DECK	OVD-7	
			CTSGT-9369CTTC	Front	
			Motor	3	
		Heads	Video Head	2Head	
			FM Audio Head	No	
			Audio /Control	Mono /Yes	
			Erase(Full Track Erase)	Yes	
		Tape	Rec	PAL	
		Speed		NTSC	
			Play	PAL	
				NTSC	
			Fast Forward / Rewind Time (Approx.)		FF:4'50"/REW:2'30" at T-120
		with Cassette			
	Forward/Reverse	NTSC or PAL-M	SP/LP/SLP=3x,5x/7x,9x/9x,15x		
	Picture Search	PAL or SECAM			
	Frame Advance		-		
	Slow Speed		-		
G-3	Tuning System	Broadcasting System		US System M	
		Tuner and	System	1Tuner	
		Receive CH	Destination	US(w/CATV)	
			Tuning System	F-Synth	
			Input Impedance	VHF/UHF 75 ohm	
			CH Coverage	2-69, 4A,A-5-A-1, A-1, J-W,W+1-W+84	
		Intermediate	Picture(FP)	45.75MHz	
		Frequency	Sound(FS)	41.25MHz	
			FP-FS	4.5MHz	
			Preset CH	No	
	Stereo/Dual TV Sound	No			
	Tuner Sound Muting	Yes			
G-4	Signal	Video Signal	Input Level	1 V p-p/75 ohm	
			Output Level	-	
			S/N Ratio (Weighted)	50 dB	
			Horizontal Resolution at SP Mode	220 Lines	
		Audio Signal	Input Level	-8dBm/50Kohm	
			Output Level	-	
			S/N Ratio at SP (Weighted)	38dB	
			Harmonic Distortion at SP(1KHz) Typical	1.5 %	
			Frequency Response at SP	100Hz - 10kHz	
			at LP	100Hz - 6kHz	
			at SLP	100Hz - 4kHz	
			Hi-Fi Audio Signal	Dynamic Range : More than	-
				Frequency Response	-
		Wow And Flutter : Less than	-		
		Channel Separation : More than	-		
		Harmonic Distortion : Less than	-		
G-5	Power	Power Source	AC	120V 60Hz	
			DC	-	
		Power Consumption		at AC 86 W at 120V 60Hz	
				at DC -	
			Stand by (at AC)	5 W at 120V 60 Hz	
			Per Year	-	
	Protector	Power Fuse	Yes		
		Safety Circuit	Yes		
		IC Protector(Micro Fuse)	No		
		Dew Sensor	No		
G-6	Regulation	Safety		UL	
		Radiation		FCC	
		X-Radiation		DHHS	
G-7	Temperature	Operation		+5°C ~ +40°C	

GENERAL SPECIFICATIONS

		Storage	-20°C ~ +60°C	
G-8	Operating Humidity		Less than 80% RH	
G-9	On Screen Display	Menu	Yes	
		Menu Type	Icon	
		System Setup	Yes	
			Clock Set	Yes
			On/Off Timer Set	Yes
			Auto Clock On/Off	Yes
			Standard Time	Yes
			Daylight Saving Time	Yes
			TV Setup	Yes
			Language	Yes
			Picture	Yes
			Audio	No
			Picture Preference	Yes
			Channel Setup	Yes
			TV/CATV	Yes
			Auto CH Memory	Yes
			Add/ Delete	Yes
			V-chip Setup	Yes
			Tape Setup	Yes
			Timer Rec Set	Yes
			Auto Repeat On/Off	Yes
			G-CODE(or SHOWVIEW or PLUSCODE)No. Entry	No
			Clock	Yes
			CH/AV(Line)	Yes
			Tape Counter(Linear Counter)	Yes
			Tape Speed	Yes
			Sleep Time	Yes
			Stereo/Audio Output	No
			Bilingual	No
			SAP	No
			Control Volume	Yes
			Level Bright / Contrast / Sharpness / Color	Yes
			Tint	Yes
			Bass/Treble/Balance	No
			Manual Tracking	Yes
			Play/Stop/FF/Rew/Rec/OTR/T-Rec/Pause/Eject/Tape In (Symbol Mark)	Yes
			Auto Tracking/Manual Tracking	Yes
	Caption / Text	Yes		
	Index	Yes		
	Mute	Yes		
	Hi-Fi	No		
	Repeat	Yes		
	Zero Return	Yes		
	DEW	No		
G-10	OSD Language		English French Spanish	
G-11	Clock,Timer and Timer Back-up	Calendar	1990/1/1 ~ 2081/12/31	
		Timer Events	8 prog/ 1 month	
		One Touch Recording Max Time	6 Hours	
		OTPB Valid Time	No	
		Sleep Timer	Max Time	
			Step	
			120 min.	
			10 min.	
	On/Off Timer	Program(On Timer / Off Timer)		
	Auto Shut Off	No Signal		
		No Operation		
		15 min.		
		-		
	Timer Back-up (at Power Off Mode)	5 sec.		
G-12	Remote Control	Unit	RC-JE	
		Glow in Dark Remocon	No	
		Format	NEC	
		Custom Code	86-02h	
		Power Source	Voltage(D.C)	
			UM size x pcs	
			3V	
			UM-4 x 2 pcs	
		Total Keys	43 Keys	
		Keys	Power	
			1	
			2	
			3	
			4	
			5	
	6			
	7			
	8			
	9			
	0			
	CH Up			

GENERAL SPECIFICATIONS

		CH Down	Yes
		Volume Up	Yes
		Volume Down	Yes
		Input Select	Yes
		Play	Yes
		F.Fwd	Yes
		Rew	Yes
		Pause/Still	Yes
		Stop	Yes
		Index+	Yes
		Index-	Yes
		Rec/OTR	Yes
		Eject	Yes
		Counter Reset	Yes
		Speed	Yes
		Timer Rec	Yes
		TV Monitor	Yes
		Quick View	Yes
		Program	Yes
		Slow	No
		Auto Tracking	Yes
		Tracking+	Yes
		Tracking -	Yes
		Menu	Yes
		Enter	Yes
		Cancel	Yes
		Call	Yes
		Closed Caption(TV/Caption/Text)	Yes
		Sleep Timer	Yes
		Mute	Yes
		Zero Return	Yes
		CM Skip(Skip Search)	Yes
		Audio Select	No
G-13	Features	Auto Head Cleaning	Yes
		Auto Tracking	Yes
		HQ (VHS Standard High Quality)	Yes
		Auto Power On, Auto Play, Auto Rewind, Auto Eject	Yes
		VIDEO PLUS+(SHOWVIEW,G-CODE)	No
		Auto Clock	Yes
		Forward / Reverse Picture Search	Yes
		One Touch Playback	No
		Auto CH Memory	Yes
		Closed Caption	Yes
		TV Auto Shut off Function	Yes
		End Call	No
		Index Search	Yes
		SQPB	No
		CATV	Yes
		CM Skip(30sec x 6 Times)	Yes
		Comb Filter	No
		TV Monitor	Yes
		Program Extend	No
		Choke Coil	No
		Energy Star	Yes
		Dirty Head	No
		V-chip USA V-chip	Yes
		CANADA V-chip	No
		CM Advance	No
		Movie Advance	No
		Zero Return	Yes
		Power On Memory	No
		Picture Preference	Yes
		Auto Setup	No
		Protect of FBT Leak Circuit	No
G-14	Accessories	Owner's Manual Language	English / Spanish
		w/Guarantee Card	Yes
		Remote Control Unit	Yes
		Battery	No
		UM size x pcs	-
		Rod Antenna	No
		Poles	-
		Terminal	-
		W/300 ohm to 75 ohm antenna adapter	-
		Loop Antenna	No
		Terminal	-
		U/V Mixer	No

GENERAL SPECIFICATIONS

		300 ohm to 75 ohm Antenna Adapter	No			
		Antenna Change Plug	No			
		DC Car Cord (Center+)	No			
		AC Plug Adapter	No			
		AC Cord	No			
		AV Cord (2Pin-1Pin)	No			
		Guarantee Card	No			
		Registration Card	No			
		ESP Card	No			
		Warning Sheet	No			
		Dew/AHC Caution Sheet	No			
		Quick Set-up Sheet	No			
		Circuit Diagram	No			
		Service Station List	No			
		Important Safeguard	No			
		Information Sheet	No			
G-15	Interface	Switch	Power	Yes		
			Play	Yes		
			Pause/Still	No		
			One Touch Playback	No		
			Channel Up	Yes		
			Channel Down	Yes		
			F.FWD/Cue	Yes		
			Eject/Stop	Yes		
			Main Power SW	No		
			Volume Up	Yes		
			Volume Down	Yes		
			Rew/Rev	Yes		
			Rec/OTR	Yes		
			Input Select	No		
			Indicator	Power	No	
				Rec/OTR	Yes	
				T-Rec	Yes	
				On Timer	No	
				CS	No	
			Key Light up	Rec/OTR	No	
				One Touch Playback	No	
				Play	No	
			Terminals	Front	Video Input	RCAX1
					Audio Input	RCAX1
			Other Terminal	Head Phone(Stereo & Mono, 3.5mm)		
		Rear	Video Input	No		
			Audio Input	No		
			Video Output	No		
			Audio Output	No		
			Euro Scart	No		
			Diversity	No		
			Ext Speaker	No		
			DC Jack 12V(Center +)	No		
			VHF/UHF Antenna Input	F Type		
			AC Inlet	No		
G-16	Set Size	Approx. W x D x H (mm)	489 x 465 x 484.5			
G-17	Weight	Net (Approx.)	19.0 kg (41.9 lbs)			
		Gross (Approx.)	22.0 kg (48.5 lbs)			
G-18	Carton	Master Carton	No			
			Content	-		
			Material	-		
			Dimensions W x D x H(mm)	-		
			Description of Origin	-		
			Gift Box	Yes		
				Material	Double/Brown	
				Dimensions W x D x H(mm)	559 x 538 x 555	
				Design	As per Buyer's	
				Description of Origin	Yes	
	Drop Test	Natural Dropping At	1 Corner / 3 Edges / 6 Surfaces			
		Height (cm)	46			
		Container Stuffing(40' container)	352 Sets			
G-19	Cabinet Material	Cabinet	Front	PS 94V0 DECABROM		
			Rear	PS 94V0 DECABROM		
			Jack Panel	-		
		PCB	Non-Halogen Demand	No		
			Eyelet Demand	No		
G-20	Environment	Pb Free	Lead-free Solder	No		
			Other	No		
		Cd Free		No		

DISASSEMBLY INSTRUCTIONS

1. REMOVAL OF MECHANICAL PARTS AND P.C. BOARDS

1-1: BACK CABINET (Refer to Fig. 1-1)

1. Remove the 7 screws (1).
2. Remove the AC cord from the AC cord hook (2).
3. Remove the Back Cabinet in the direction of arrow.

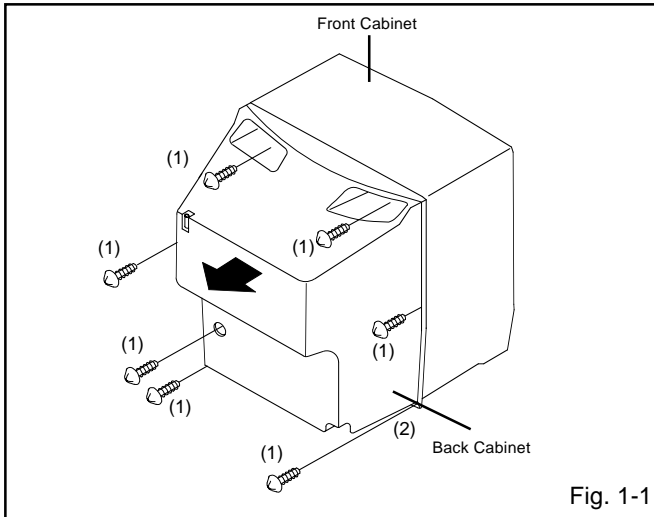

Fig. 1-1

1-2: CRT PCB (Refer to Fig. 1-2)

CAUTION: BEFORE REMOVING THE ANODE CAP, DISCHARGE ELECTRICITY BECAUSE IT CONTAINS HIGH VOLTAGE. BEFORE ATTEMPTING TO REMOVE OR REPAIR ANY PCB, UNPLUG THE POWER CORD FROM THE AC SOURCE.

1. Remove the Anode Cap. (Refer to REMOVAL OF ANODE CAP)
2. Disconnect the following connectors: (CP801 and CP851B).
3. Remove the CRT PCB in the direction of arrow.

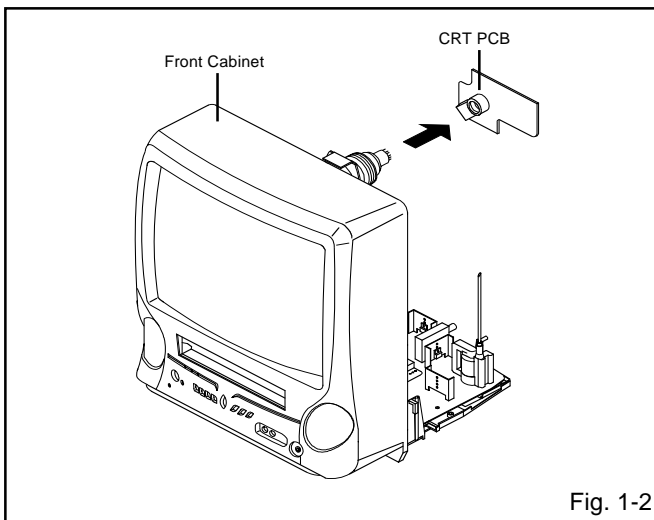

Fig. 1-2

1-3: TV/VCR BLOCK (Refer to Fig. 1-3)

1. Remove the 2 screws (1).
2. Disconnect the following connectors: (CP354, CP401 and CP502).
3. Unlock the support (2).
4. Remove the TV/VCR Block in the direction of arrow.

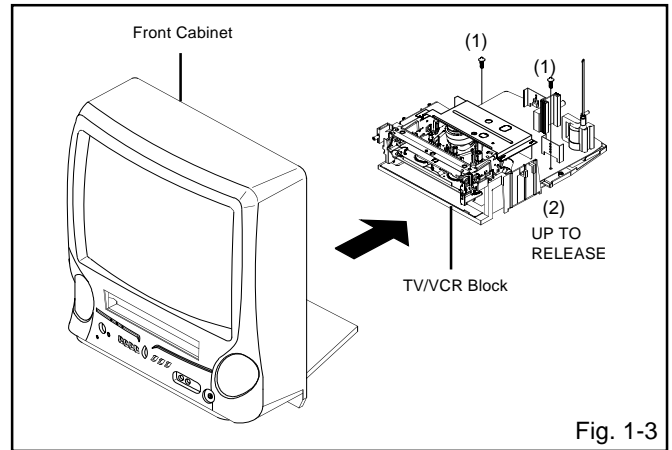

Fig. 1-3

1-4: DECK CHASSIS AND SYSCON PCB (Refer to Fig. 1-4)

NOTE

Do not remove the cable at the FE Head section. The FE Head may be damaged if you remove the cable by force.

1. Remove the screw (1).
2. Remove the FE Head.
3. Remove the 2 screws (2).
4. Remove the 3 screws (3).
5. Remove the screw (4).
6. Remove the Deck Shield Plate in direction of arrow (A).
7. Remove the 2 screws (5).
8. Disconnect the following connectors: (CP1001, CP4001, CP4002 and CP4003).
9. Remove the Deck Chassis in the direction of arrow (B).
10. Remove the screw (6).
11. Remove the Syscon PCB in the direction of arrow (C).

DISASSEMBLY INSTRUCTIONS

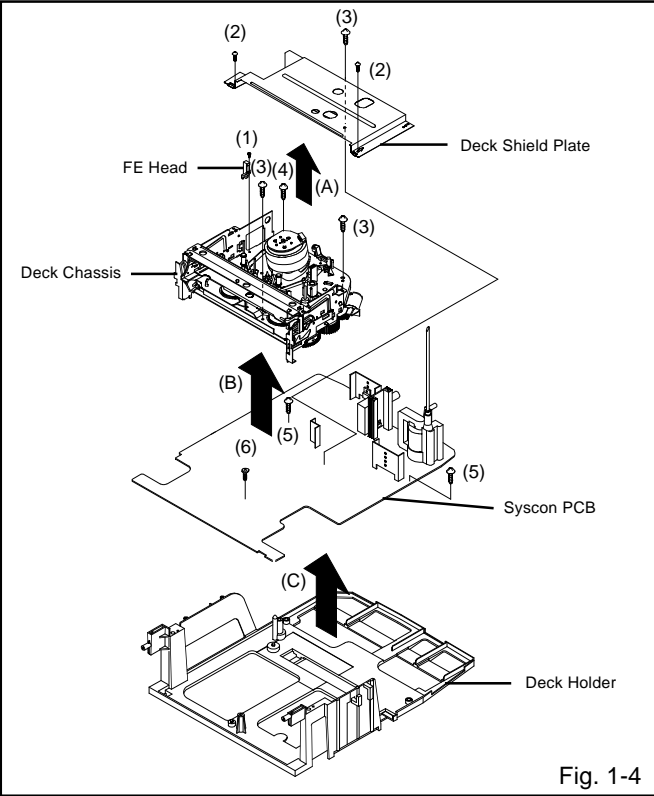

Fig. 1-4

DISASSEMBLY INSTRUCTIONS

2. REMOVAL OF VCR DECK PARTS

2-1: TOP BRACKET (Refer to Fig. 2-1)

1. Extend the 2 supports (1).
2. Slide the 2 supports (2) and remove the Top Bracket.

NOTE

1. After the installation of the Top Bracket, bend the support (1) so that the Top Bracket is fixed.

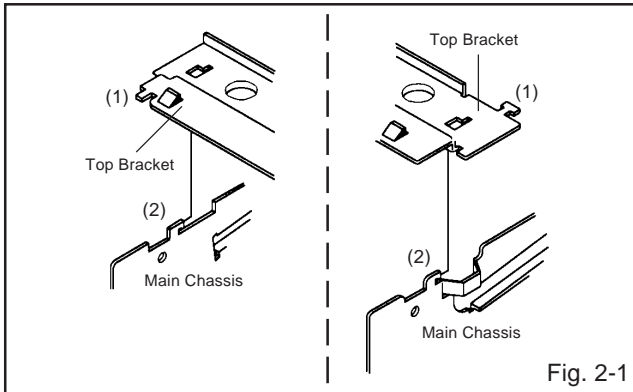

Fig. 2-1

2-2: CASSETTE HOLDER ASS'Y (Refer to Fig. 2-2)

1. Move the Cassette Holder Ass'y to the front side.
2. Push the Locker R to remove the Cassette Side R.
3. Remove the Cassette Side L.

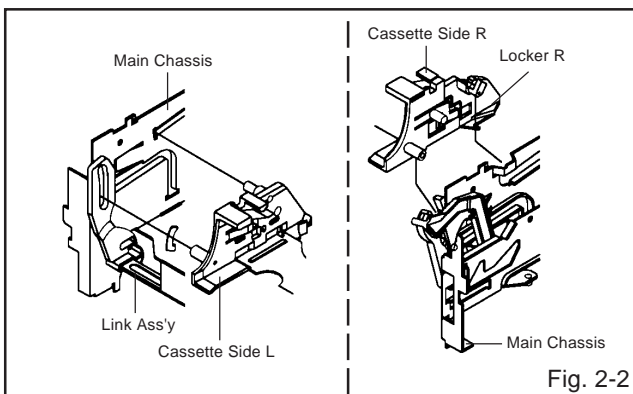

Fig. 2-2

2-3: CASSETTE SIDE L/R (Refer to Fig. 2-3-A)

1. Remove the Locker Spring.
2. Unlock the 4 supports (1) and then remove the Cassette Side L/R.
3. Unlock the support (2) and then remove the Locker R.

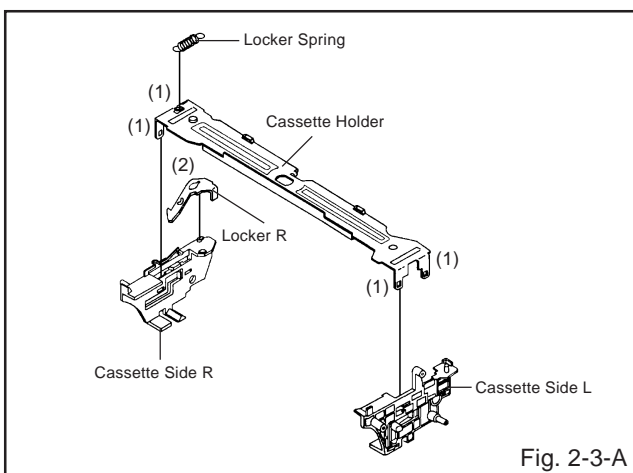

Fig. 2-3-A

NOTE

1. In case of the Locker R installation, check if the one position of Fig.2-3-B is correctly locked.
2. When you install the Cassette Side R, be sure to move the Locker R after installing.

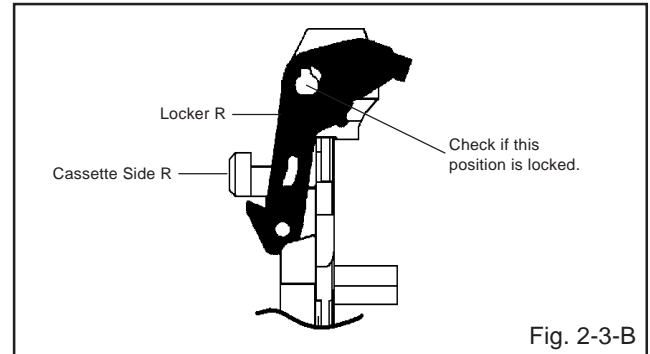

Fig. 2-3-B

2-4: LINK UNIT (Refer to Fig. 2-4)

1. Set the Link Unit to the Eject position.
2. Unlock the support (1).
3. Remove the (A) side of the Link Unit first, then remove the (B) side.

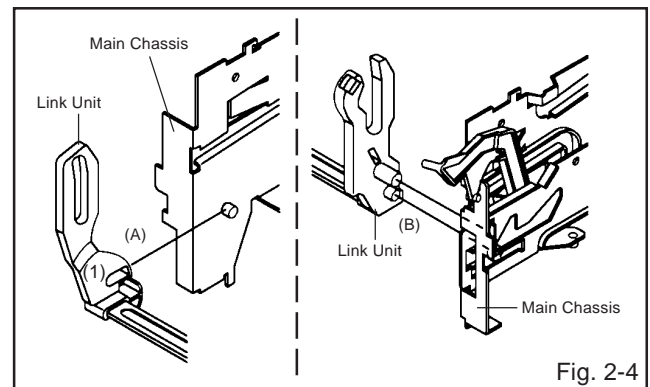

Fig. 2-4

2-5: LINK LEVER/FLAP LEVER/BOT COVER (Refer to Fig. 2-5)

1. Unlock the support (1).
2. Remove the BOT Cover.
3. Extend the support (2).
4. Remove the Link Lever.
5. Remove the Flap Lever.

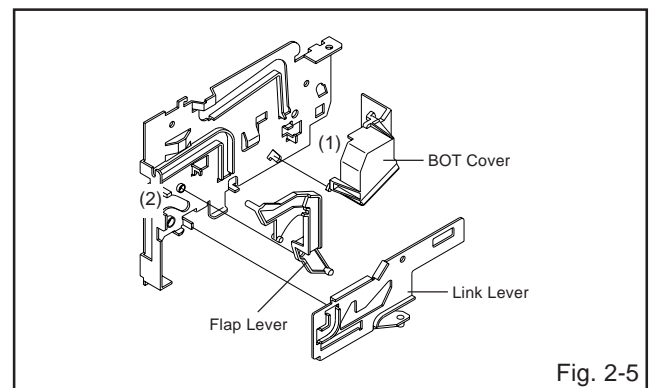
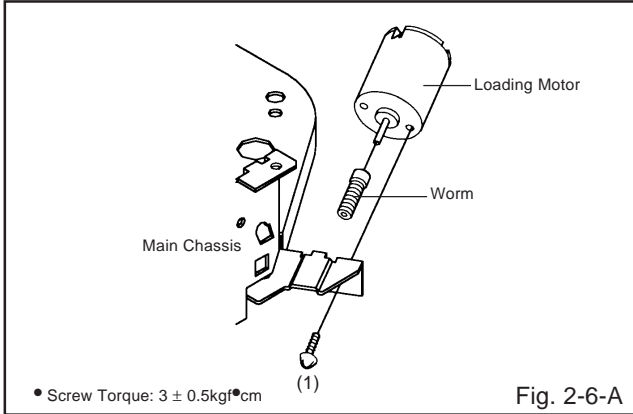

Fig. 2-5

DISASSEMBLY INSTRUCTIONS

2-6: LOADING MOTOR/WORM (Refer to Fig. 2-6-A)

1. Remove the screw (1).
2. Remove the Loading Motor.
3. Remove the Worm.



NOTE

1. In case of the Worm installation, check if the value of the Fig. 2-6-B is correct.
2. In case of the Loading Motor installation, hook the wire on the Cassette Opener as shown Fig. 2-6-C.
3. When installing the wires between Capstan DD Unit and Loading Motor, connect them correctly as shown Fig. 2-6-D.

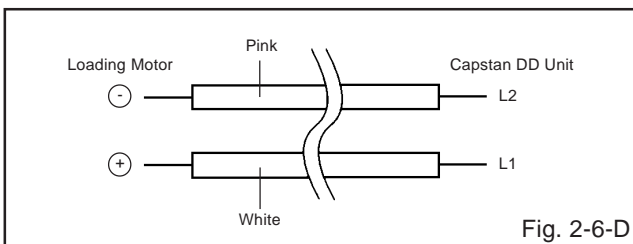
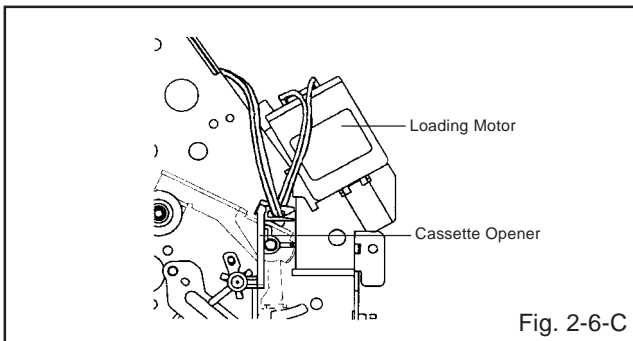
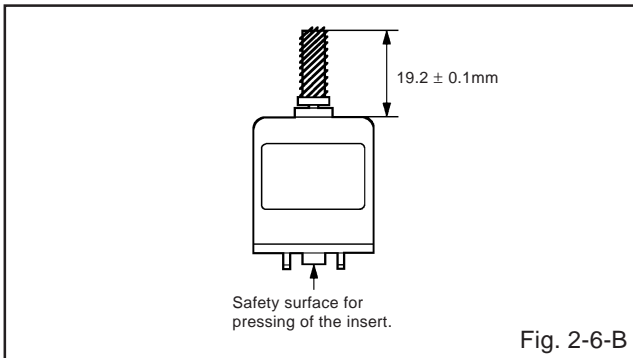

2-7: TENSION ASS'Y (Refer to Fig. 2-7-B)

1. Turn the Pinch Roller Cam clockwise so that the Tension Holder hook is set to the position of Fig. 2-7-A to move the Tension Arm Ass'y.
2. Remove the Tension Spring.
3. Unlock the 2 supports (1) and remove the Tension Band.
4. Unlock the support (2) and remove the Tension Arm Ass'y.
5. Unlock the support (3) and remove the Tension Connect.
6. Float the hook (4) and turn it clockwise then remove the Tension Holder.

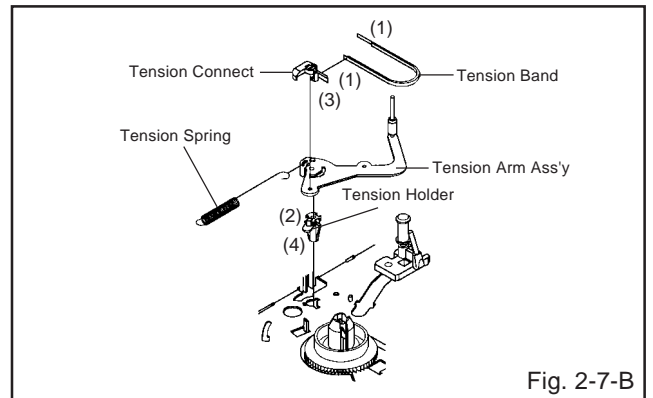
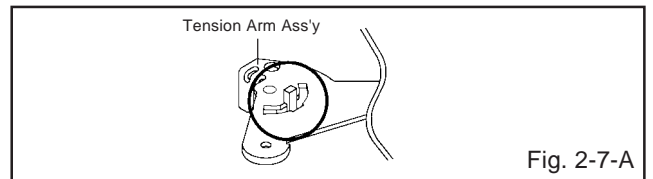

NOTE

1. In case of the Tension Band installation, note the direction of the installation. (Refer to Fig. 2-7-C)
2. In case of the Tension Band installation, install correctly as Fig. 2-7-D.
3. In case of the Tension Connect installation, install as the circled section of Fig. 2-7-E.

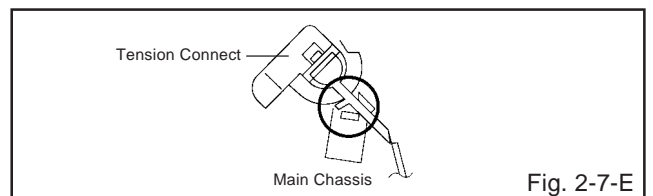
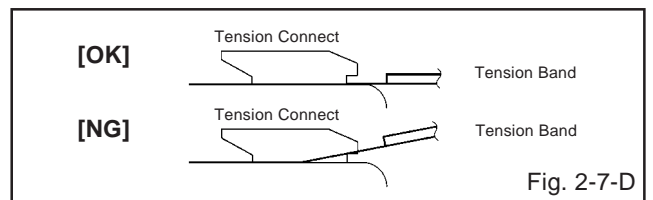
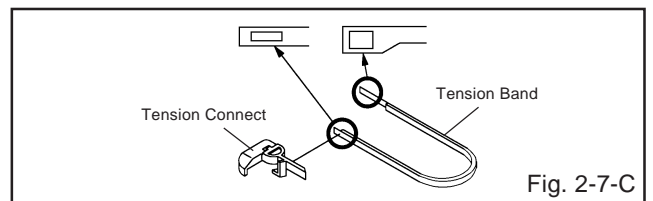

DISASSEMBLY INSTRUCTIONS

2-8: T BRAKE ARM/T BRAKE BAND (Refer to Fig. 2-8-A)

1. Remove the T Brake Spring.
2. Turn the T Brake Arm clockwise and bend the hook section to remove it.
3. Unlock the 2 supports (1) and remove the T Brake Band.

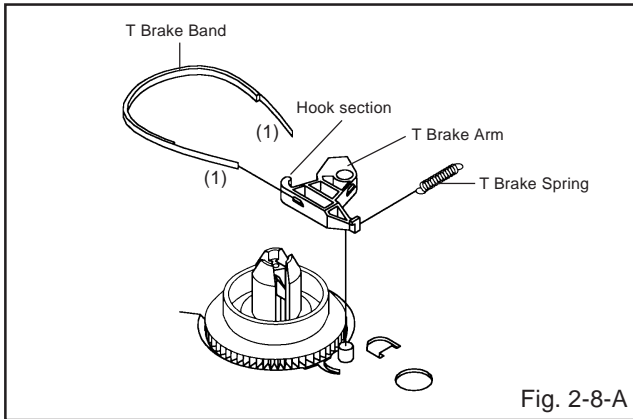

Fig. 2-8-A

NOTE

1. In case of the T Brake Band installation, install correctly as Fig. 2-8-B.

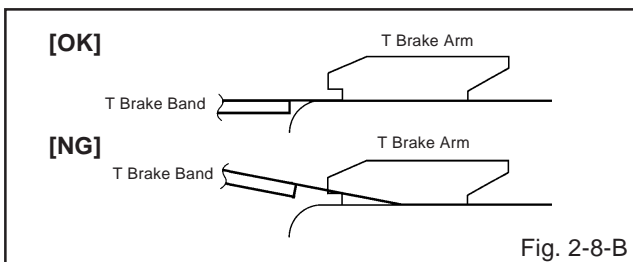

Fig. 2-8-B

2-9: S REEL/T REEL/IDLER ARM ASS'Y/IDLER GEAR (Refer to Fig. 2-9-A)

1. Remove the S Reel and T Reel.
2. Remove the 2 Polyslider Washers (1).
3. Remove the Idler Arm Ass'y and Idler Gear.

NOTE

1. Take care not to damage the gears of the S Reel and T Reel.
2. The Polyslider Washer may be remained on the back of the reel.
3. Take care not to damage the shaft.
4. Do not touch the section "A" of S Reel and T Reel. (Use gloves.) (Refer to Fig. 2-9-A) Do not adhere the stains on it.
5. When you install the reel, clean the shaft and grease it (FG-84M). (If you do not grease, noise may be heard in FF/REW mode.)
6. After installing the reel, adjust the height of the reel. (Refer to MECHANICAL ADJUSTMENT)

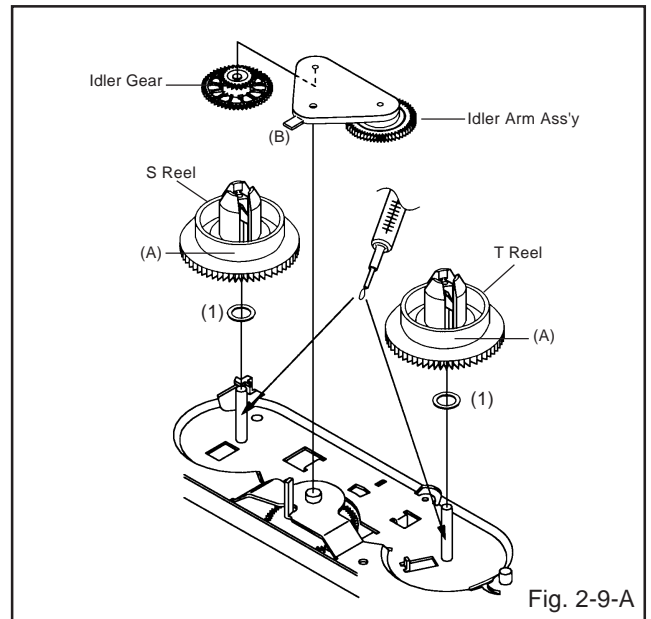

Fig. 2-9-A

NOTE

1. In case of the S Reel and T Reel installation, check if the correct parts are installed. (Refer to Fig. 2-9-B)
2. In case of the Idler Arm Ass'y installation, install correctly as Fig. 2-9-C, And also set it so that the section "B" of Fig. 2-9-A is placed under the Main Chassis tab.

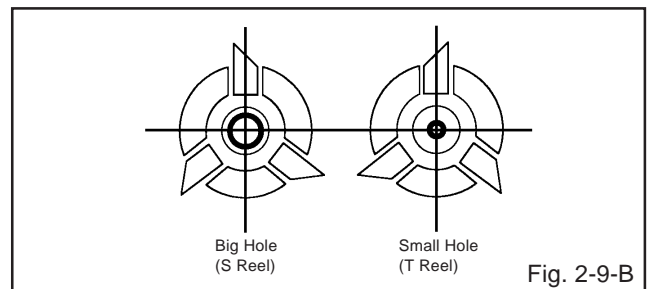

Fig. 2-9-B

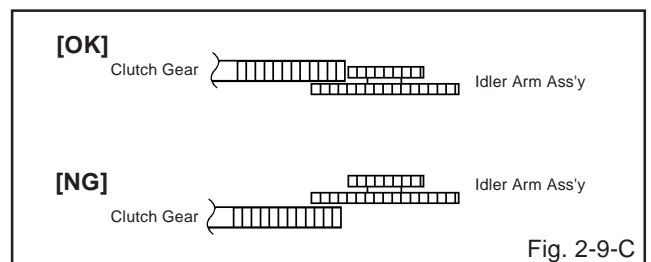
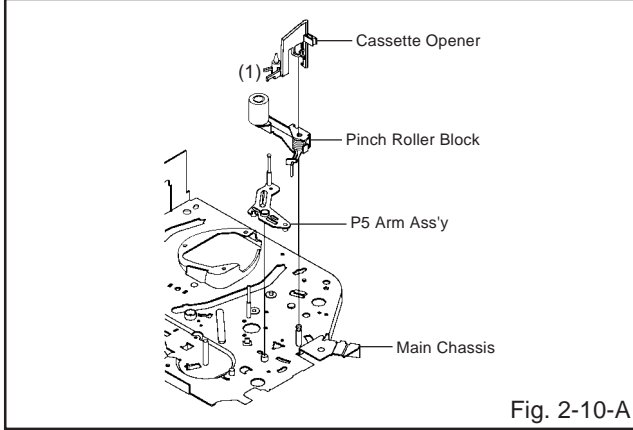

Fig. 2-9-C

DISASSEMBLY INSTRUCTIONS

2-10: CASSETTE OPENER/PINCH ROLLER BLOCK/ P5 ARM ASS'Y (Refer to Fig. 2-10-A)

1. Unlock the support (1) and remove the Cassette Opener.
2. Remove the Pinch Roller Block and P5 Arm Ass'y.



NOTE

1. Do not touch the Pinch Roller. (Use gloves.)
2. In case of the Pinch Roller Block and the Pinch Roller Cam installation, install correctly as Fig. 2-10-B.

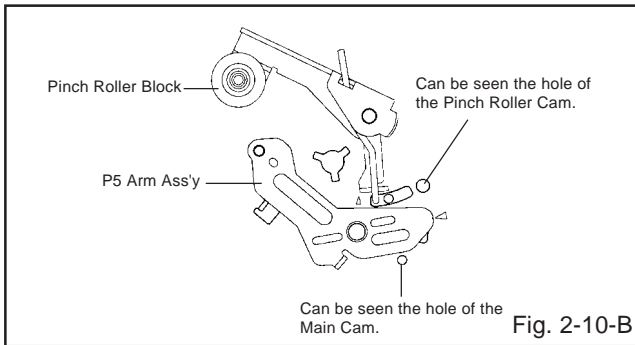

2-11: A/C HEAD (Refer to Fig. 2-11-A)

1. Remove the screw (1).
2. Remove the A/C Head Base.
3. Remove the 3 screws (2).
4. Remove the A/C Head and A/C Head Spring.

NOTE

1. Do not touch the A/C Head. (Use gloves.)
2. When you install the A/C Head Spring, install as shown in Fig. 2-11-B.
3. When you install the A/C Head, tighten the screw (1) first, then tighten the screw (2), finally tighten the screw (3).

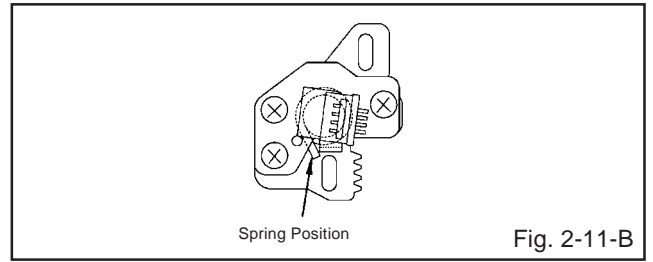
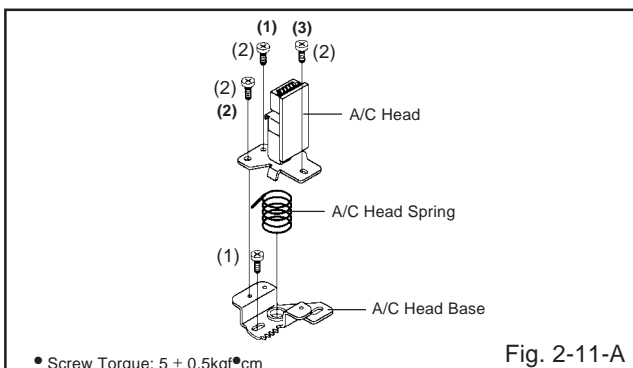

2-12: FE HEAD (RECORDER ONLY) (Refer to Fig. 2-12)

1. Remove the screw (1).
2. Remove the FE Head.

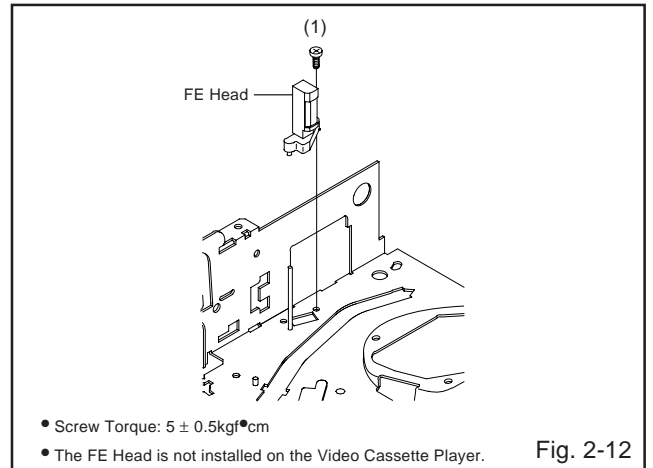

2-13: AHC ASS'Y/CYLINDER UNIT ASS'Y (Refer to Fig. 2-13)

1. Unlock the support (1) and remove the AHC Ass'y.
2. Disconnect the following connector: (CD2001)
3. Remove the 3 screws (2).
4. Remove the Cylinder Unit Ass'y.

NOTE

1. When you install the Cylinder Unit Ass'y, tighten the screws from (1) to (3) in order while pulling the Ass'y toward the left front direction.

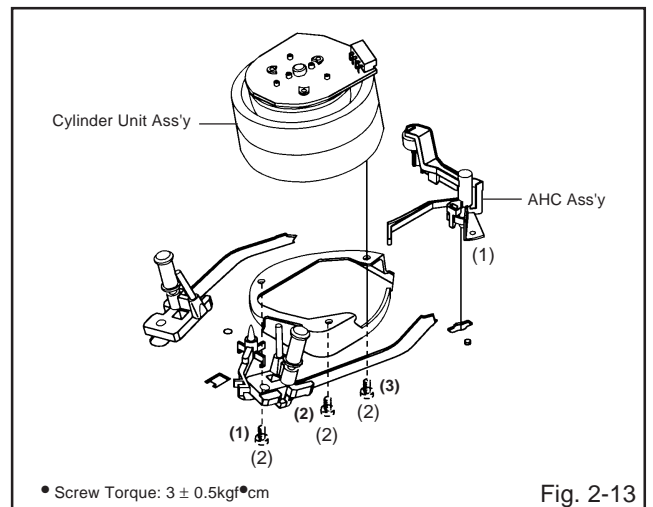

DISASSEMBLY INSTRUCTIONS

2-14: CAPSTAN DD UNIT (Refer to Fig. 2-14-A)

1. Remove the Capstan Belt.
2. Remove the 3 screws (1).
3. Remove the Capstan DD Unit.

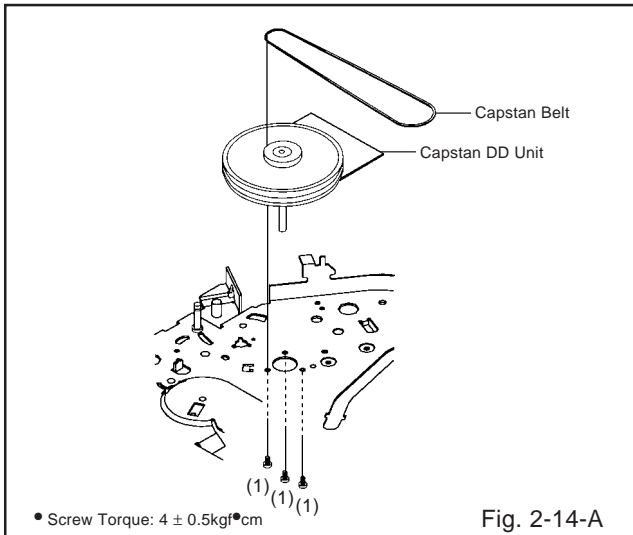

NOTE

1. In case of the Capstan DD Unit installation, apply the silicon bond (TSE3843-W) on the position Fig. 2-14-B correctly. (If no silicon bond applied, abnormal noise will be heard on the deck operation.)
(Refer to Fig. 2-14-B, C)

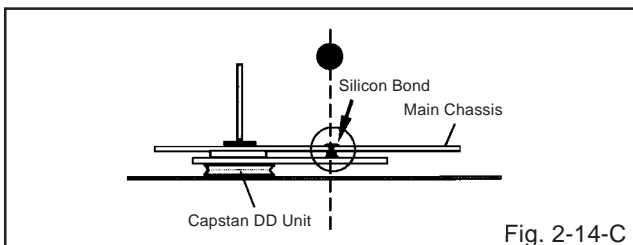
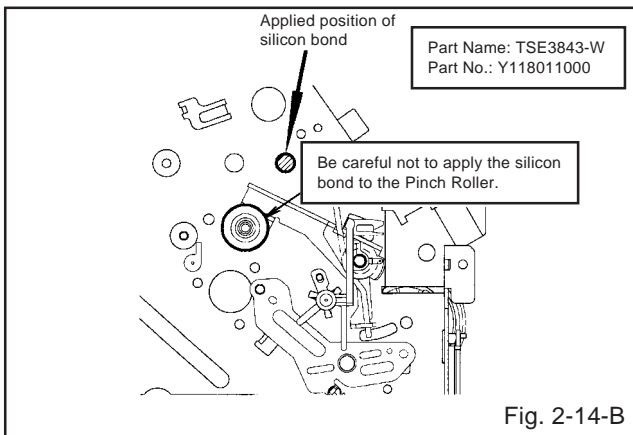

2-15: MAIN CAM/PINCH ROLLER CAM/JOINT GEAR (Refer to Fig. 2-15-A)

1. Remove the E-Ring (1), then remove the Main Cam.
2. Remove the E-Ring (2), then remove the Pinch Roller Cam and Joint Gear.

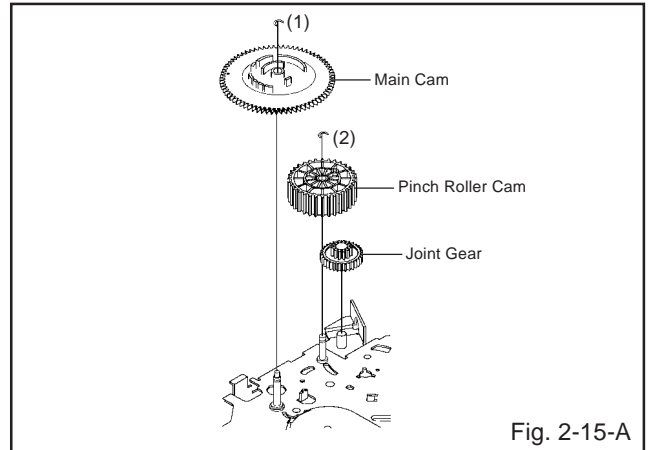

NOTE

1. In case of the Pinch Roller Cam and Main Cam installation, install them as the circled section of Fig. 2-15-B so that the each markers are met.
(Refer to Fig. 2-15-B)

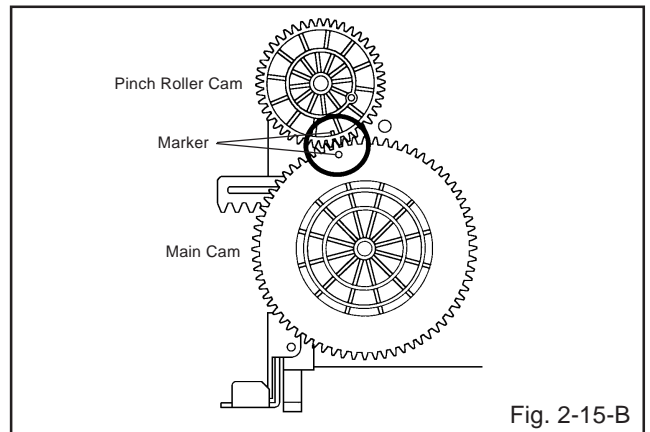

2-16: LOADING GEAR S/T UNIT (Refer to Fig. 2-16-A)

1. Remove the E-Ring (1) and remove the Main Loading Gear.
2. Remove the Main Rod, Tension Lever, Loading Arm S Unit and Loading Arm T Unit.

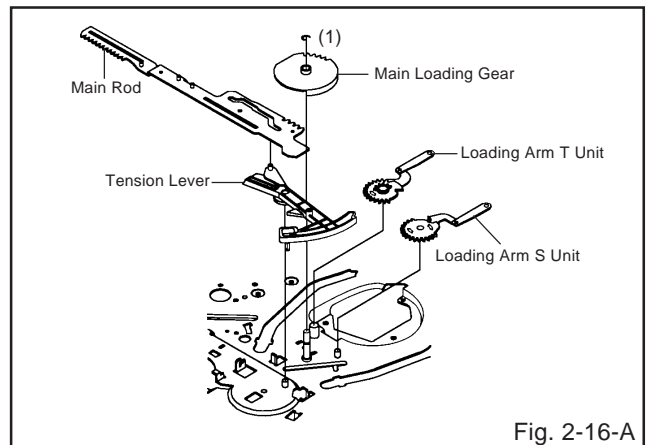

DISASSEMBLY INSTRUCTIONS

NOTE

1. When you install the Loading Arm S Unit, Loading Arm T Unit and Main Loading Gear, align each marker. (Refer to Fig. 2-16-B)

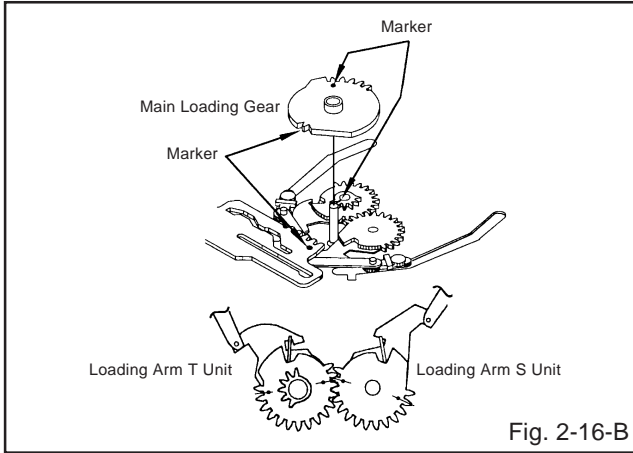

2-17: CLUTCH ASS'Y/RING SPRING/CLUTCH LEVER/CLUTCH GEAR (Refer to Fig. 2-17-A)

1. Remove the Polyslider Washer (1).
2. Remove the Clutch Ass'y and Ring Spring.
3. Remove the Clutch Lever.
4. Remove the Coupling Gear, Coupling Spring and Clutch Gear.

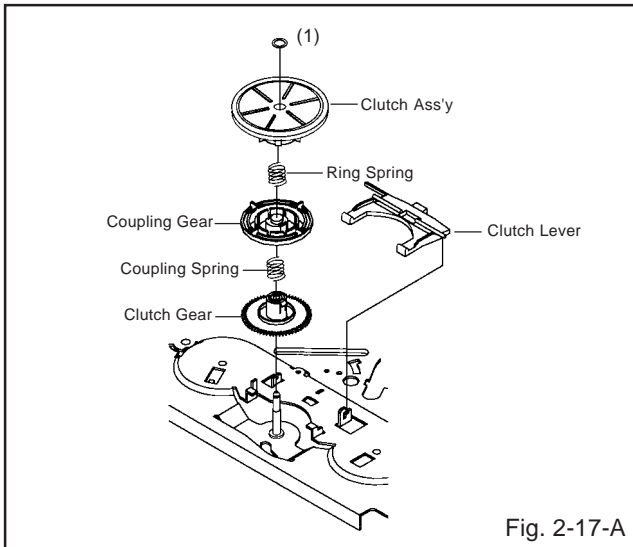

NOTE

1. In case of the Clutch Ass'y installation, install it with inserting the spring of the Clutch Ass'y into the dent of the Coupling Gear. (Refer to Fig. 2-17-B)

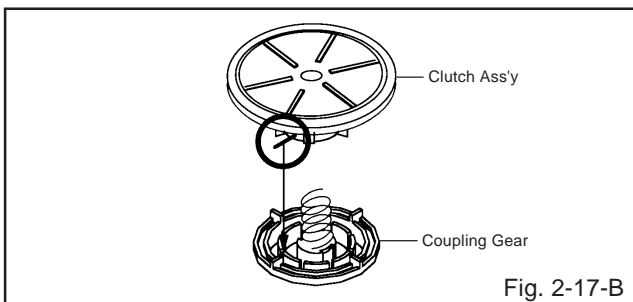

2-18: CASSETTE GUIDE POST/INCLINED BASE S/T UNIT/P4 CAP/LED REFLECTOR (Refer to Fig. 2-18-A)

1. Remove the P4 Cap.
2. Unlock the support (1) and remove the Cassette Guide Post.
3. Remove the Inclined Base S/T Unit.
4. Remove the screw (2)
5. Remove the LED Reflector.

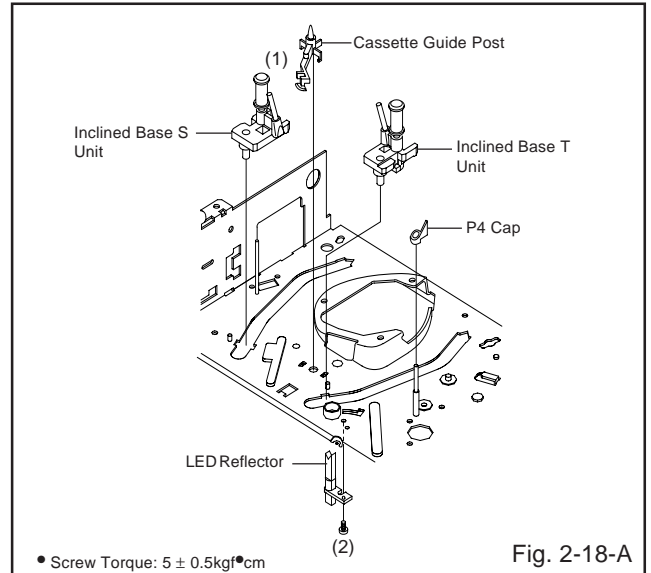

NOTE

1. Do not touch the roller of Guide Roller.
2. In case of the P4 Cap installation, install it with parallel for "A" and "B" of Fig. 2-18-B.
3. In case of the Cassette Guide Post installation, install correctly as the circled section of Fig. 2-18-C.

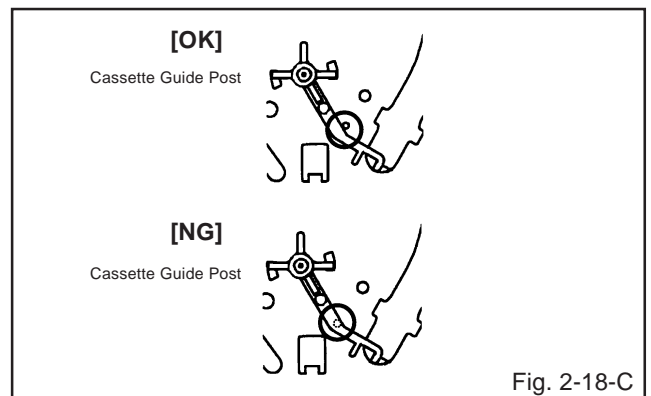
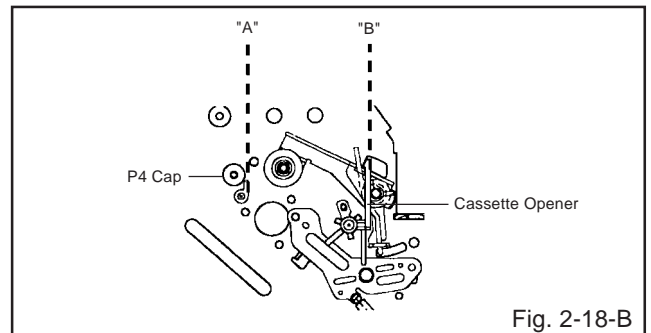

DISASSEMBLY INSTRUCTIONS

3. REMOVAL OF ANODE CAP

Read the following **NOTED** items before starting work.

- * After turning the power off there might still be a potential voltage that is very dangerous. When removing the Anode Cap, make sure to discharge the Anode Cap's potential voltage.
- * Do not use pliers to loosen or tighten the Anode Cap terminal, this may cause the spring to be damaged.

REMOVAL

1. Follow the steps as follows to discharge the Anode Cap. **(Refer to Fig. 3-1.)**

Connect one end of an Alligator Clip to the metal part of a flat-blade screwdriver and the other end to ground. While holding the plastic part of the insulated Screwdriver, touch the support of the Anode with the tip of the Screwdriver.

A cracking noise will be heard as the voltage is discharged.

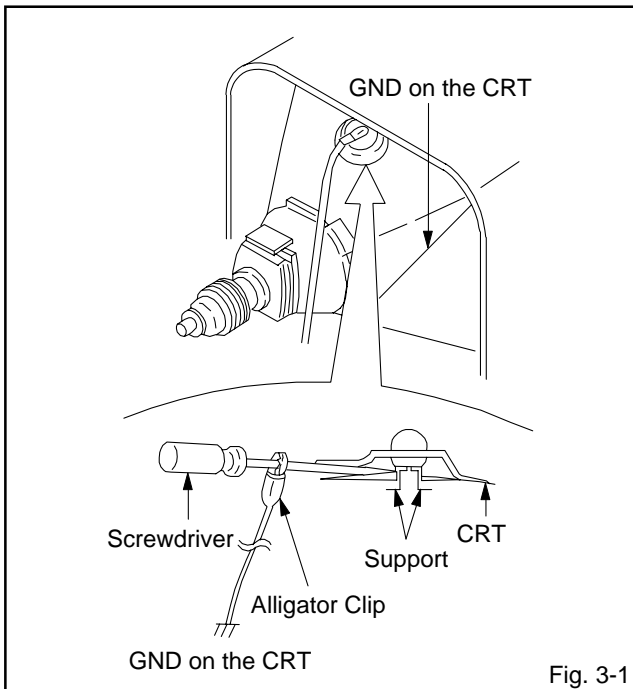

Fig. 3-1

2. Flip up the sides of the Rubber Cap in the direction of the arrow and remove one side of the support. **(Refer to Fig. 3-2.)**

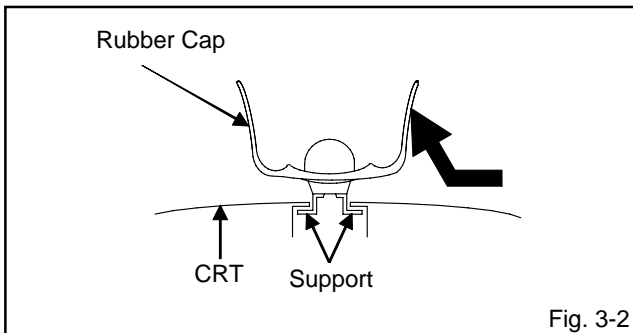

Fig. 3-2

3. After one side is removed, pull in the opposite direction to remove the other.

NOTE

Take care not to damage the Rubber Cap.

INSTALLATION

1. Clean the spot where the cap was located with a small amount of alcohol. **(Refer to Fig. 3-3.)**

NOTE

Confirm that there is no dirt, dust, etc. at the spot where the cap was located.

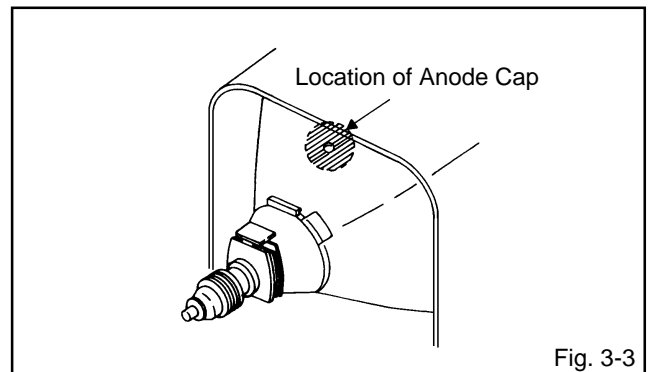

Fig. 3-3

2. Arrange the wire of the Anode Cap and make sure the wire is not twisted.
3. Turn over the Rubber Cap. **(Refer to Fig. 3-4.)**

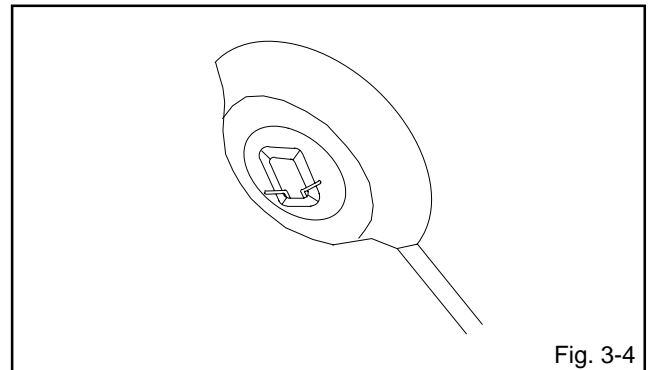

Fig. 3-4

4. Insert one end of the Anode Support into the anode button, then the other as shown in **Fig. 3-5.**

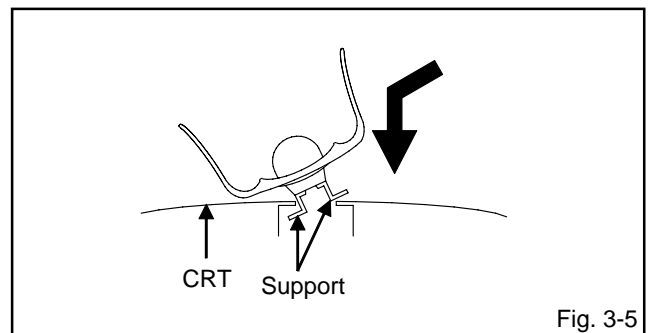

Fig. 3-5

5. Confirm that the Support is securely connected.
6. Put on the Rubber Cap without moving any parts.

DISASSEMBLY INSTRUCTIONS

4. REMOVAL AND INSTALLATION OF FLAT PACKAGE IC

REMOVAL

1. Put the Masking Tape (cotton tape) around the Flat Package IC to protect other parts from any damage. (Refer to Fig. 4-1.)

NOTE

Masking is carried out on all the parts located within 10 mm distance from IC leads.

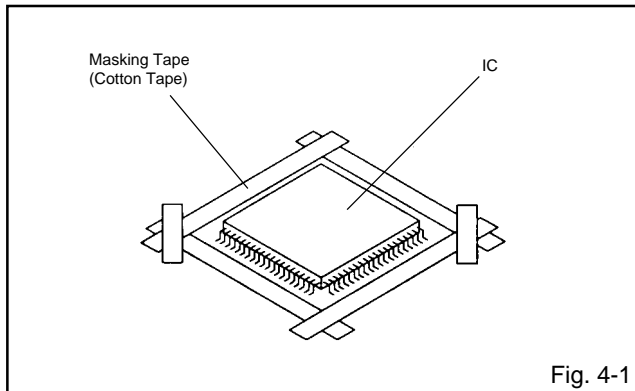

2. Heat the IC leads using a blower type IC desoldering machine. (Refer to Fig. 4-2.)

NOTE

Do not add the rotating and the back and forth directions force on the IC, until IC can move back and forth easily after desoldering the IC leads completely.

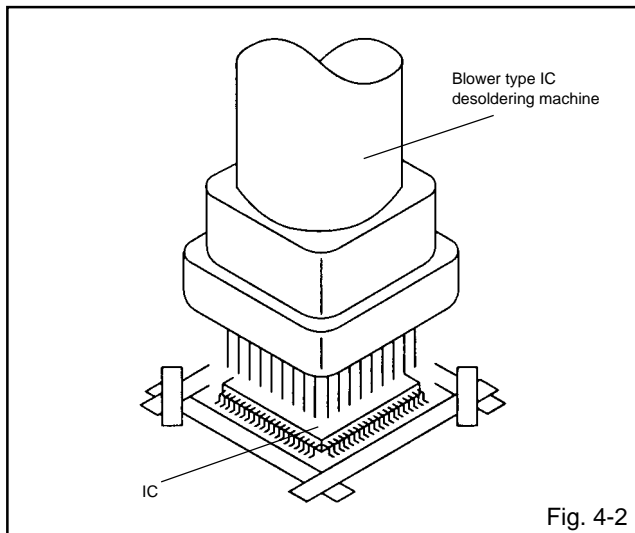

3. When IC starts moving back and forth easily after desoldering completely, pickup the corner of the IC using a tweezers and remove the IC by moving with the IC desoldering machine. (Refer to Fig. 4-3.)

NOTE

Some ICs on the PCB are affixed with glue, so be careful not to break or damage the foil of each IC leads or solder lands under the IC when removing it.

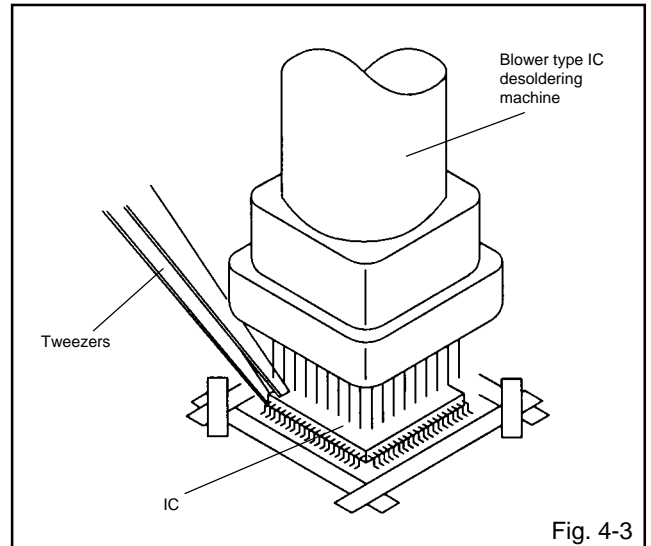

4. Peel off the Masking Tape.
5. Absorb the solder left on the pattern using the Braided Shield Wire. (Refer to Fig. 4-4.)

NOTE

Do not move the Braided Shield Wire in the vertical direction towards the IC pattern.

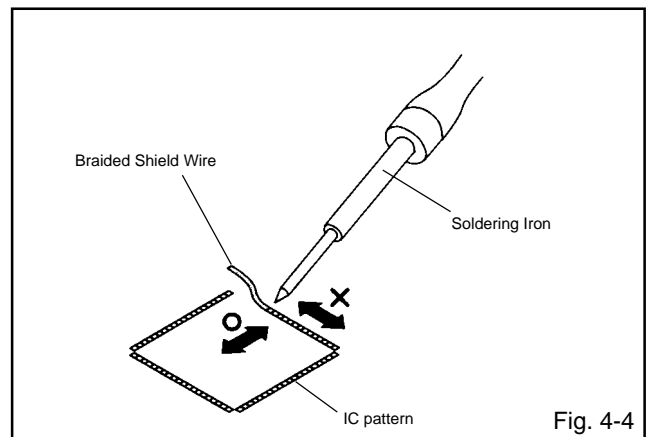

DISASSEMBLY INSTRUCTIONS

INSTALLATION

1. Take care of the polarity of new IC and then install the new IC fitting on the printed circuit pattern. Then solder each lead on the diagonal positions of IC temporarily. (Refer to Fig. 4-5.)

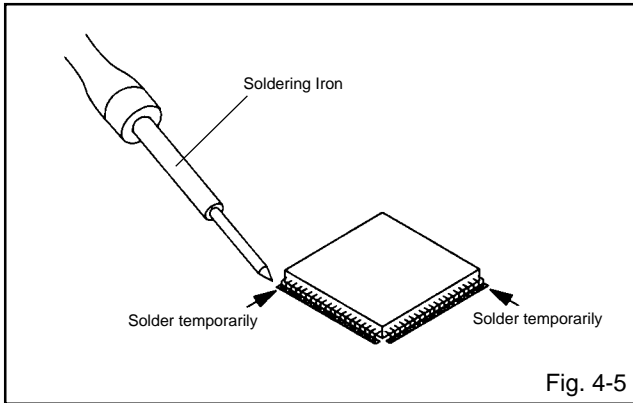

Fig. 4-5

2. Supply the solder from the upper position of IC leads sliding to the lower position of the IC leads. (Refer to Fig. 4-6.)

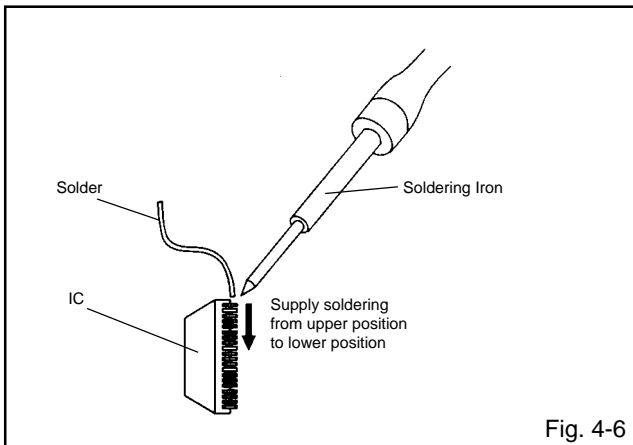

Fig. 4-6

3. Absorb the solder left on the lead using the Braided Shield Wire. (Refer to Fig. 4-7.)

NOTE

Do not absorb the solder to excess.

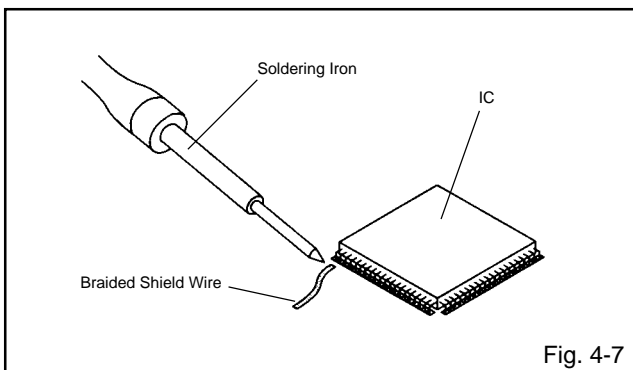

Fig. 4-7

4. When bridge-soldering between terminals and/or the soldering amount are not enough, resolder using a Thin-tip Soldering Iron. (Refer to Fig. 4-8.)

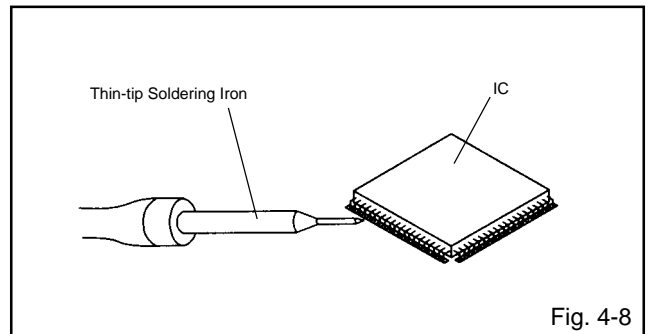

Fig. 4-8

5. Finally, confirm the soldering status on four sides of the IC using a magnifying glass. Confirm that no abnormality is found on the soldering position and installation position of the parts around the IC. If some abnormality is found, correct by resoldering.

NOTE

When the IC leads are bent during soldering and/or repairing, do not repair the bending of leads. If the bending of leads are repaired, the pattern may be damaged. So, be always sure to replace the IC in this case.

KEY TO ABBREVIATIONS

A	A/C	: Audio/Control	H.SW	: Head Switch	
	ACC	: Automatic Color Control	Hz	: Hertz	
	AE	: Audio Erase	I	IC	: Integrated Circuit
	AFC	: Automatic Frequency Control		IF	: Intermediate Frequency
	AFT	: Automatic Fine Tuning		IND	: Indicator
	AFT DET	: Automatic Fine Tuning Detect		INV	: Inverter
	AGC	: Automatic Gain Control	K	KIL	: Killer
	AMP	: Amplifier	L	L	: Left
	ANT	: Antenna		LED	: Light Emitting Diode
	A.PB	: Audio Playback		LIMIT AMP	: Limiter Amplifier
	APC	: Automatic Phase Control		LM, LDM	: Loading Motor
	ASS'Y	: Assembly		LP	: Long Play
	AT	: All Time		L.P.F	: Low Pass Filter
	AUTO	: Automatic		LUMI.	: Luminance
	A/V	: Audio/Video	M	M	: Motor
B	BGP	: Burst Gate Pulse		MAX	: Maximum
	BOT	: Beginning of Tape		MINI	: Minimum
	BPF	: Bandpass Filter		MIX	: Mixer, mixing
	BRAKE SOL	: Brake Solenoid		MM	: Monostable Multivibrator
	BUFF	: Buffer		MOD	: Modulator, Modulation
	B/W	: Black and White		MPX	: Multiplexer, Multiplex
C	C	: Capacitance, Collector		MS SW	: Mecha State Switch
	CASE	: Cassette	N	NC	: Non Connection
	CAP	: Capstan		NR	: Noise Reduction
	CARR	: Carrier	O	OSC	: Oscillator
	CH	: Channel		OPE	: Operation
	CLK	: Clock	P	PB	: Playback
	CLOCK (SY-SE)	: Clock (Syscon to Servo)		PB CTL	: Playback Control
	COMB	: Combination, Comb Filter		PB-C	: Playback-Chrominance
	CONV	: Converter		PB-Y	: Playback-Luminance
	CPM	: Capstan Motor		PCB	: Printed Circuit Board
	CTL	: Control		P. CON	: Power Control
	CYL	: Cylinder		PD	: Phase Detector
	CYL-M	: Cylinder-Motor		PG	: Pulse Generator
	CYL SENS	: Cylinder-Sensor		P-P	: Peak-to Peak
D	DATA (SY-CE)	: Data (Syscon to Servo)	R	R	: Right
	dB	: Decibel		REC	: Recording
	DC	: Direct Current		REC-C	: Recording-Chrominance
	DD Unit	: Direct Drive Motor Unit		REC-Y	: Recording-Luminance
	DEMODO	: Demodulator		REEL BRK	: Reel Brake
	DET	: Detector		REEL S	: Reel Sensor
	DEV	: Deviation		REF	: Reference
E	E	: Emitter		REG	: Regulated, Regulator
	EF	: Emitter Follower		REW	: Rewind
	EMPH	: Emphasis		REV, RVS	: Reverse
	ENC	: Encoder		RF	: Radio Frequency
	ENV	: Envelope		RMC	: Remote Control
	EOT	: End of Tape		RY	: Relay
	EQ	: Equalizer	S	S. CLK	: Serial Clock
	EXT	: External		S. COM	: Sensor Common
F	F	: Fuse		S. DATA	: Serial Data
	FBC	: Feed Back Clamp		SEG	: Segment
	FE	: Full Erase		SEL	: Select, Selector
	FF	: Fast Forward, Flipflop		SENS	: Sensor
	FG	: Frequency Generator		SER	: Search Mode
	FL SW	: Front Loading Switch		SI	: Serial Input
	FM	: Frequency Modulation		SIF	: Sound Intermediate Frequency
	FSC	: Frequency Sub Carrier		SO	: Serial Output
	FWD	: Forward		SOL	: Solenoid
G	GEN	: Generator		SP	: Standard Play
	GND	: Ground		STB	: Serial Strobe
H	H.P.F	: High Pass Filter		SW	: Switch

KEY TO ABBREVIATIONS

S	SYNC	:	Synchronization
	SYNC SEP	:	Sync Separator, Separation
T	TR	:	Transistor
	TRAC	:	Tracking
	TRICK PB	:	Trick Playback
	TP	:	Test Point
U	UNREG	:	Unregulated
V	V	:	Volt
	VCO	:	Voltage Controlled Oscillator
	VIF	:	Video Intermediate Frequency
	VP	:	Vertical Pulse, Voltage Display
	V.PB	:	Video Playback
	VR	:	Variable Resistor
	V.REC	:	Video Recording
	VSF	:	Visual Search Fast Forward
	VSR	:	Visual Search Rewind
	VSS	:	Voltage Super Source
	V-SYNC	:	Vertical-Synchronization
	VT	:	Voltage Tuning
X	X'TAL	:	Crystal
Y	Y/C	:	Luminance/Chrominance

SERVICE MODE LIST

This unit provided with the following SERVICE MODES so you can repair, examine and adjust easily.

To enter SERVICE MODE, unplug AC cord till lost actual clock time. Then press and hold Vol (-) button of main unit and remocon key simultaneously.

The both pressing of set key and remote control key will not be possible if clock has been set. To reset clock, either unplug AC cord and allow at least 5 seconds before Power On.

Set Key	Remocon Key	Operations
VOL. (-) MIN	0	Releasing of V-CHIP PASSWORD.
VOL. (-) MIN	1	Initialization of the factory. NOTE: Do not use this for the normal servicing. If you set a factory initialization, the memories are reset such as the clock setting, the channel setting, the POWER ON total hours, and PLAY/REC total hours.
VOL. (-) MIN	2	Horizontal position adjustment of OSD. NOTE: Also can be adjusted by using the Adjustment MENU. Refer to the "ELECTRICAL ADJUSTMENT" (OSD HORIZONTAL).
VOL. (-) MIN	3	Adjust the PG SHIFTER automatically. Refer to the "ELECTRICAL ADJUSTMENT" (PG SHIFTER).
VOL. (-) MIN	4	Adjust the PG SHIFTER manually. Refer to the "ELECTRICAL ADJUSTMENT" (PG SHIFTER).
VOL. (-) MIN	5	Adjusting of the Tracking to the center position. NOTE: Also can be adjusted by pressing the ATR button for more than 2 seconds during PLAY.
VOL. (-) MIN	6	POWER ON total hours and PLAY/REC total hours are displayed on the screen. Refer to the "PREVENTIVE CHECKS AND SERVICE INTERVALS" (CONFIRMATION OF HOURS USED). Can be checked of the INITIAL DATA of MEMORY IC. Refer to the "WHEN REPLACING EEPROM (MEMORY) IC".
VOL. (-) MIN	8	Writing of EEPROM initial data. NOTE: Do not use this for the normal servicing.
VOL. (-) MIN	9	Display of the Adjustment MENU on the screen. Refer to the "ELECTRICAL ADJUSTMENT" (On-Screen Display Adjustment).

Method	Operations
Press the ATR button on the remote control for more than 2 seconds during PLAY.	Adjusting of the Tracking to the center position. Refer to the "MECHANICAL ADJUSTMENT" (GUIDE ROLLER) and "ELECTRICAL ADJUSTMENT" (PG SHIFTER).
Make the short circuit between the test point of SERVICE and the GND.	The BOT, EOT and the Reel Sensor do not work and the deck can be operated without a cassette tape. Refer to the "PREPARATION FOR SERVICING"

PREVENTIVE CHECKS AND SERVICE INTERVALS

The following standard table depends on environmental conditions and usage.

Parts replacing time does not mean the life span for individual parts.

Also, long term storage or misuse may cause transformation and aging of rubber parts.

The following list means standard hours, so the checking hours depends on the conditions.

Time Parts Name	500 hours	1,000 hours	1,500 hours	2,000 hours	2,500 hours	Notes
Audio Control Head	■	■	■	●	●	Clean those parts in contact with the tape.
Full Erase Head (Recorder only)	■	■	■	●	●	
Capstan Belt		●	●	●	●	Clean the rubber, and parts which the rubber touches.
Pinch Roller	■	●	●	●	●	
Capstan DD Unit		●	●	●	●	
Loading Motor					●	
Tension Band		●	●	●	●	
T Brake Band		●	●	●	●	
Clutch Ass'y		●	●	●	●	
Idler Arm Ass'y		●	●	●	●	
Capstan Shaft	■	■	■	■	■	
Tape Running Guide Post	■	■	■	■	■	Replace when rolling becomes abnormal.
Cylinder Unit	■	●	●	●	●	Clean the Head

■ : Clean

● : Check it and if necessary, replace it.

CONFIRMATION OF HOURS USED

POWER ON total hours and PLAY/REC total hours can be checked on the screen.

Total hours are displayed in 16 system of notation.

NOTE: If you set a factory initialization, the total hours is reset to "0".

The confirmation of using hours will not be possible if clock has been set. To reset clock, either unplug AC cord and allow at least 5 seconds before Power On.

1. Set the VOLUME to minimum.
2. Press both VOL. DOWN button on the set and the Channel button (6) on the remote control simultaneously.
3. After the confirmation of using hours, turn off the power.

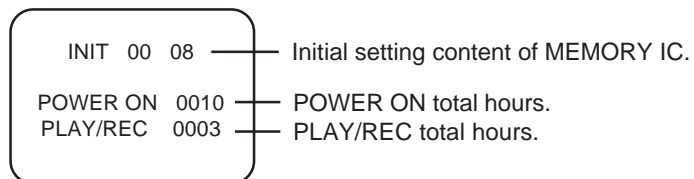

(16 x 16 x 16 x thousands digit value) + (16 x 16 x hundreds digit value) + (16 x tens digit value) + (ones digit value)

PREVENTIVE CHECKS AND SERVICE INTERVALS

CLEANING

NOTE

After cleaning the heads with isopropyl alcohol, do not run a tape until the heads dry completely. If the heads are not completely dry and alcohol gets on the tape, damage may occur.

1. AUDIO CONTROL HEAD

Clean the Audio Control Head with the cotton stick soaked by alcohol. Clean the full erase head in the same manner. **(Refer to the figure below.)**

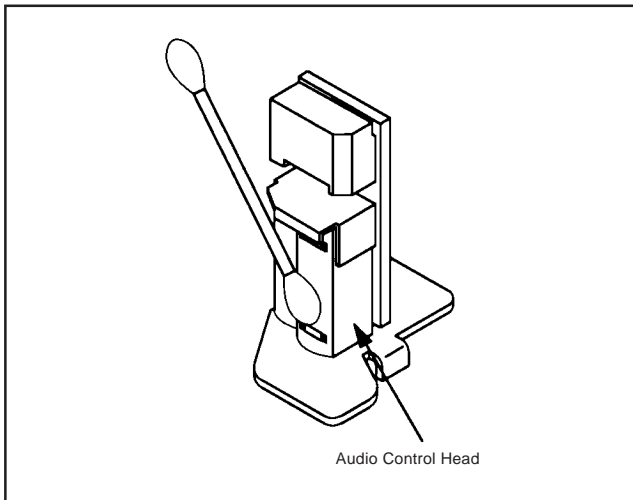

2. TAPE RUNNING SYSTEM

When cleaning the tape transport system, use the gauze moistened with isopropyl alcohol.

3. CYLINDER

Wrap a piece of chamois around your finger. Dip it in isopropyl alcohol. Hold it to the cylinder head softly. Turn the cylinder head counterclockwise to clean it (in the direction of the arrow). **(Refer to the figure below.)**

NOTE

Do not exert force against the cylinder head. Do not move the chamois upward or downward on the head. Use the chamois one by one.

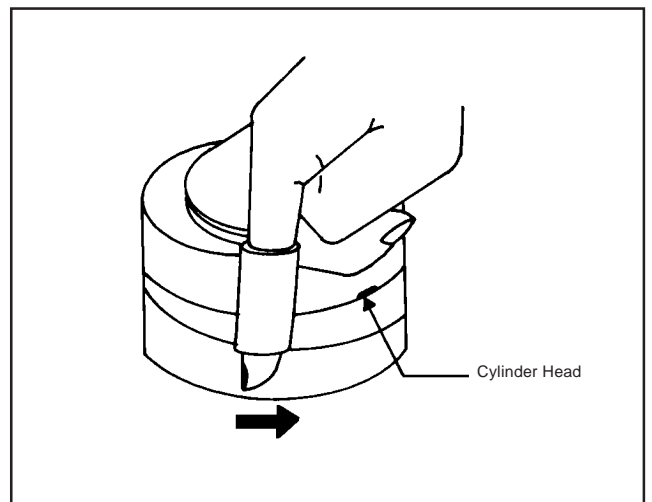

WHEN REPLACING EEPROM (MEMORY) IC

If a service repair is undertaken where it has been required to change the MEMORY IC, the following steps should be taken to ensure correct data settings while making reference to TABLE 1.

NOTE: No need setting for after INI 35 due to the adjustment value.

INI	+0	+1	+2	+3	+4	+5	+6	+7	+8	+9	+A	+B	+C	+D	+E	+F
00	08	0A	70	69	C2	B3	24	A9	51	2C	40	A6	00	40	00	10
10	B2	9A	92	93	00	11	00	05	08	82	A9	0F	94	45	06	14
20	06	3A	01	25	54	60	23	3B	DA	D7	00	00	00	00	00	38
30	88	08	88	98	88	04	---	---	---	---	---	---	---	---	---	---

Table 1

1. Enter DATA SET mode by setting VOLUME to minimum.
2. While holding down VOLUME button on front cabinet, press key 6 on remote control. ADDRESS and DATA should appear as FIG 1.

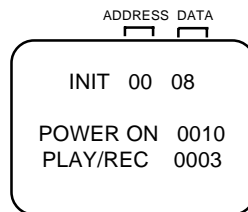

Fig. 1



3. ADDRESS is now selected and should "blink". Using the SET +/- button on the remote, step through the ADDRESS until required ADDRESS to be changed is reached.
4. Press ENTER to select DATA. When DATA is selected, it will "blink".
5. Again, step through the DATA using SET +/- button until required DATA value has been selected.
6. Pressing ENTER will take you back to ADDRESS for further selection if necessary.
7. Repeat steps 3 to 6 until all data has been checked.
8. When satisfied correct DATA has been entered, turn POWER off (return to STANDBY MODE) to finish DATA input.

After the data input, set to the initializing of shipping.

9. Turn POWER on.
10. While holding down VOLUME button on front cabinet, press key 1 on remote control.
11. After the finishing of the initializing of shipping, the unit will turn off automatically.

The unit will now have the correct DATA for the new MEMORY IC.

SERVICING FIXTURES AND TOOLS

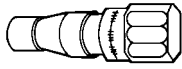
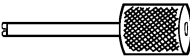
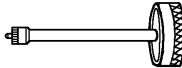
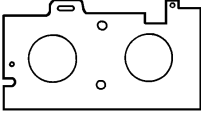
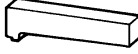
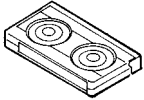
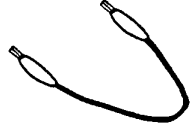
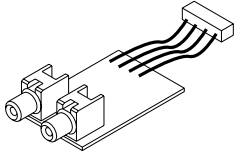
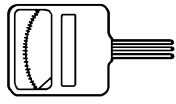
<p>(For 2 heads model) VHS Alignment Tape JG001 (VN₂S-LI6³) JG001A (VN₂S-CO¹³) JG001Q (VN₂S-LI6³ H) JG001T (VN₂S-X6³)</p> 	<p>(For 4 heads model) VHS Alignment Tape JG001B (VN₁S-LI6³) JG001I (VN₁S-CO¹³) JG001P (VN₁S-LI6³ H) JG001S (VN₁S-X6³)</p> 	<p>JG002B Adapter JG002E Dial Torque Gauge (10~90gf•cm) JG002F (60~600gf•cm)</p> 	<p>JG005 Post Adjustment Screwdriver Part No. SV-TG0-030-000 (small)</p> 
<p>JG153 X Value Adjustment Screwdriver</p> 	<p>JG022 Master Plane</p> 	<p>JG024A Reel Disk Height Adjustment Jig</p> 	<p>JG100A Torque Tape (VHT-063)</p> 
<p>JG154 Cable</p> 	<p>JG180 AV Jack Jig</p> 	<p>JG185 Tentelometer</p> 	

Ref. No.	Part No.	Parts Name	Remarks
JG001	APJG001000	VHS Alignment Tape	Monoscope, 6KHz (For 2 heads model)
JG001A	APJG001A00	VHS Alignment Tape	Color Bar, 1KHz (For 2 heads model)
JG001Q	APJG001Q00	VHS Alignment Tape	Hi-Fi Audio (For 2 heads model)
JG001T	APJG001T00	VHS Alignment Tape	X Value Adjustment (For 2 heads model)
JG001B	APJG001B00	VHS Alignment Tape	Monoscope, 6KHz (For 4 heads model)
JG001I	APJG001I00	VHS Alignment Tape	Color Bar, 1KHz (For 4 heads model)
JG001P	APJG001P00	VHS Alignment Tape	Hi-Fi Audio (For 4 heads model)
JG001S	APJG001S00	VHS Alignment Tape	X Value Adjustment (For 4 heads model)
JG002B	APJG002B00	Adapter	VSR Torque, Brake Torque (S Reel/T Reel Ass'y)
JG002E	APJG002E00	Dial Torque Gauge (10~90gf•cm)	Brake Torque (T Reel Ass'y)
JG002F	APJG002F00	Dial Torque Gauge (60~600gf•cm)	VSR Torque, Brake Torque (S Reel)
JG005	APJG005000	Post Adjustment Screwdriver	Guide Roller Adjustment
JG153	APJG153000	X Value Adjustment Screwdriver	X Value Adjustment
JG022	APJG022000	Master Plane	Reel Disk Height Adjustment
JG024A	APJG024A00	Reel Disk Height Adjustment Jig	Reel Disk Height Adjustment
JG100A	APJG100A00	Torque Tape (VHT-063)	Playback Torque, Back Tension Torque During Playback
JG154	APJG154000	Cable	Used to connect the test point of SERVICE and GROUND
JG180	APJG180000	AV Jack Jig	PG Shifter Adjustment, Color Level Adjustment, E-E Level Adjustment
JG185	APJG185000	Tentelometer	Confirmation of Tape Tension on Playback

PREPARATION FOR SERVICING

How to use the Servicing Fixture

- Remove the Syscon PCB from the set.
Be sure to place the parts on a paper so that they have no short-circuit each other.
- Short circuit between **TP1001** and **Ground** with the cable JG154.
(The BOT, EOT and the Reel Sensor do not work and the deck can be operated without a cassette tape.)
- In case of using a cassette tape, press the STOP/EJECT button to insert or eject a cassette tape.
Turn on the power and re-check the cable before checking the trouble points.

MECHANICAL ADJUSTMENTS

1. CONFIRMATION AND ADJUSTMENT

Read the following NOTES before starting work.

- Place an object which weighs between 450g~500g on the Cassette Tape to keep it steady when you want to make the tape run without the Cassette Holder. (Do not place an object which weighs over 500g.)

1-1: CONFIRMATION AND ADJUSTMENT OF REEL DISK HEIGHT

- Turn on the power and set to the STOP mode.
- Set the master plane (**JG022**) and reel disk height adjustment jig (**JG024A**) on the mechanism framework, taking care not to scratch the drum, as shown in **Fig. 1-1-A**.
- While turning the reel and confirm the following points. Check if the surface "A" of reel disk is lower than the surface "B" of reel disk height adjustment jig (**JG024A**) and is higher than the surface "C". If it is not passed, place the height adjustment washers and adjust to $10(+2, -0)$ mm.
- Adjust the other reel in the same way.

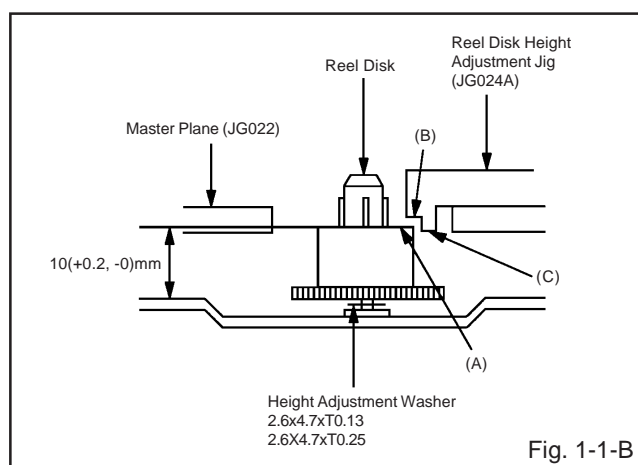
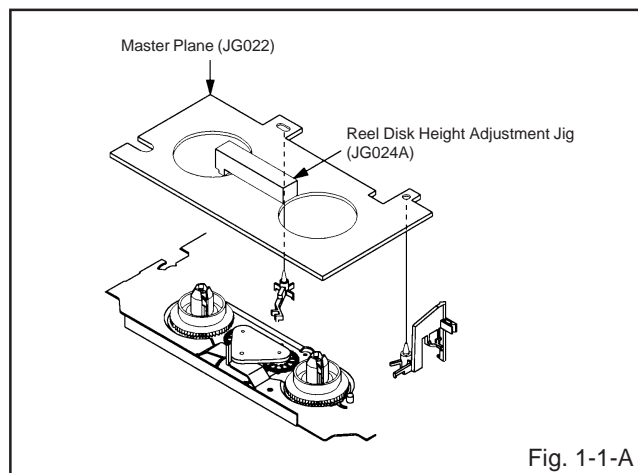

1-2: CONFIRMATION AND ADJUSTMENT OF TENSION POST POSITION

- Set to the PLAY mode.
- Adjust the adjusting section for the Tension Arm position so that the Tension Arm top is within the standard line of Main Chassis.
- While turning the S Reel clockwise, confirm that the edge of the Tension Arm is located in the position described above.

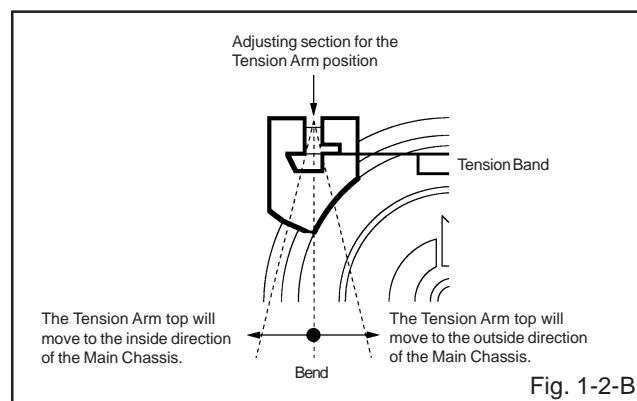
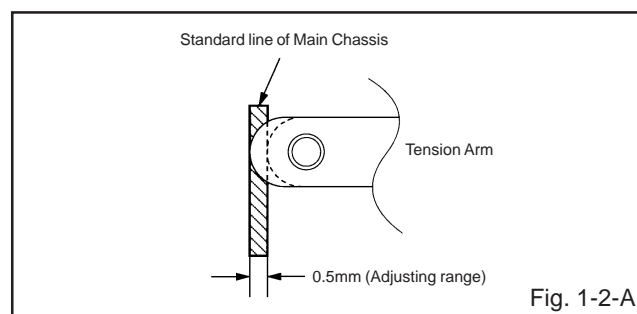

1-3: CONFIRMATION OF PLAYBACK TORQUE AND BACK TENSION TORQUE DURING PLAYBACK

- Load a video tape (T-120) recorded in standard speed mode. Set the unit to the PLAY mode.
- Install the tentelometer (JG185) as shown in **Fig. 1-3**. Confirm that the meter indicates 20 ± 2 gf in the beginning of playback.

• USING A CASSETTE TYPE TORQUE TAPE (**JG100A**)

- After confirmation and adjustment of Tension Post position (Refer to item 1-2), load the cassette type torque tape (**JG100A**) and set to the PLAY mode.
- Confirm that the right meter of the torque tape indicates $50\sim 90$ gf•cm during playback in SP mode.
- Confirm that the left meter of the torque tape indicates $25\sim 40$ gf•cm during playback in SP mode.

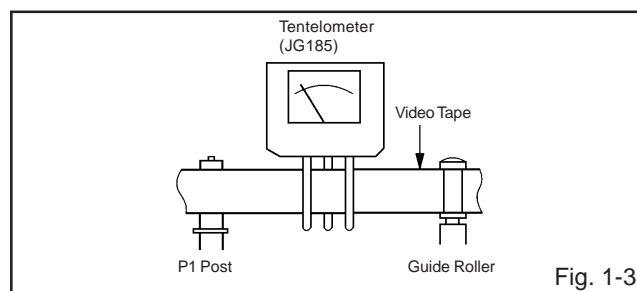

MECHANICAL ADJUSTMENTS

1-4: CONFIRMATION OF VSR TORQUE

1. Install the Torque Gauge (**JG002F**) and Adapter (**JG002B**) on the S Reel. Set to the Picture Search (Rewind) mode. (Refer to Fig.1-4-B)
2. Then, confirm that it indicates 120~180gf•cm.

NOTE

Install the Torque Gauge on the reel disk firmly. Press the REW button to turn the reel disk.

1-5: CONFIRMATION OF REEL BRAKE TORQUE

(S Reel Brake) (Refer to Fig. 1-4-B)

1. Once set to the Fast Forward mode then set to the Stop mode. While, unplug the AC cord when the Pinch Roller Block is on the position of Fig. 1-4-A.
2. Move the Idler Ass'y from the S Reel.
3. Install the Torque Gauge (**JG002F**) and Adapter (**JG002B**) on the S Reel. Turn the Torque Gauge (**JG002F**) clockwise.
4. Then, confirm that it indicates 60~100gf•cm.

(T Reel Brake) (Refer to Fig. 1-4-B)

1. Once set to the Fast Forward mode then set to the Stop mode. While, unplug the AC cord when the Pinch Roller Block is on the position of Fig. 1-4-A.
2. Move the Idler Ass'y from the T Reel.
3. Install the Torque Gauge (**JG002E**) and Adapter (**JG002B**) on the T reel. Turn the Torque Gauge (**JG002E**) counterclockwise.
4. Then, confirm that it indicates 30~50gf•cm.

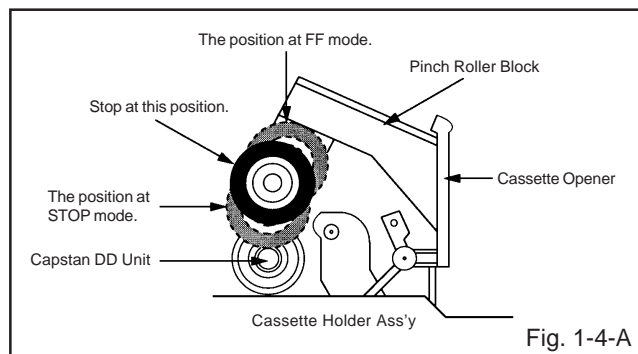

Fig. 1-4-A

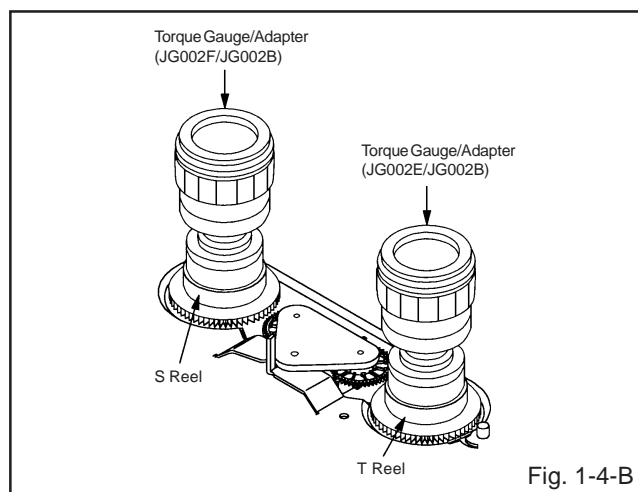

Fig. 1-4-B

NOTE

If the torque is out of the range, replace the following parts.

Check item	Replacement Part
1-4	Idler Ass'y/Clutch Ass'y
1-5	S Reel side: S Reel/Tension Band/Tension Connect/Tension Arm Ass'y T Reel side: T Reel/T Brake Band/T Brake Spring/T Brake Arm

2. CONFIRMATION AND ADJUSTMENT OF TAPE RUNNING MECHANISM

Tape Running Mechanism is adjusted precisely at the factory. Adjustment is not necessary as usual. When you replace the parts of the tape running mechanism because of long term usage or failure, the confirmation and adjustment are necessary.

2-1: GUIDE ROLLER

1. Playback the VHS Alignment Tape (**JG001** or **JG001B**). (Refer to **SERVICING FIXTURE AND TOOLS**)
2. Connect CH-1 of the oscilloscope to **TP4001 (Envelope)** and CH-2 to **TP1002 (SW Pulse)**.
3. Press and hold the ATR button on the remote control more than 2 seconds to set tracking to center.
4. Trigger with SW Pulse and observe the envelope. (Refer to Fig. 2-1-A)
5. When observing the envelope, adjust the Adjusting Driver (**JG005**) slightly until the envelope will be flat. Even if you press the Tracking Button, adjust so that flatness is not moved so much.
6. Adjust so that the A : B ratio is better than 3 : 2 as shown in Fig. 2-1-B, even if you press the Tracking Button to move the envelope (The envelope waveform will begin to decrease when you press the Tracking Button).
7. Adjust the PG shifter during playback. (Refer to the **ELECTRICAL ADJUSTMENTS**)

NOTE

After adjustment, confirm and adjust A/C head. (Refer to item 2-2)

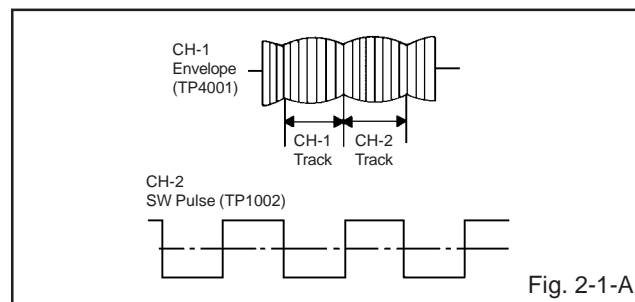

Fig. 2-1-A

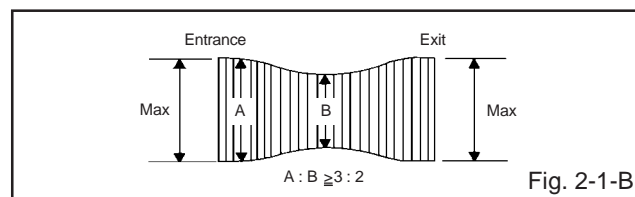

Fig. 2-1-B

MECHANICAL ADJUSTMENTS

2-2: CONFIRMATION AND ADJUSTMENT OF AUDIO/CONTROL HEAD

When the Tape Running Mechanism does not work well, adjust the following items.

1. Playback the VHS Alignment Tape (**JG001 or JG001B**). (Refer to **SERVICING FIXTURE AND TOOLS**)
2. Confirm that the reflected picture of stamp mark is appeared on the tape prior to P4 Post as shown in **Fig. 2-2-A**.
 - a) When the reflected picture is distorted, turn the screw (1) clockwise until the distortion is disappeared.
 - b) When the reflected picture is not distorted, turn the screw (1) counterclockwise until little distortion is appeared, then adjust the a).
3. Turn the screw (2) to set the audio level to maximum.
4. Confirm that the bottom of the Audio/Control Head and the bottom of the tape is shown in **Fig. 2-2-C**.
 - c) When the height is not correct, turn the screw (3) to adjust the height. Then, adjust the 1~3 again.

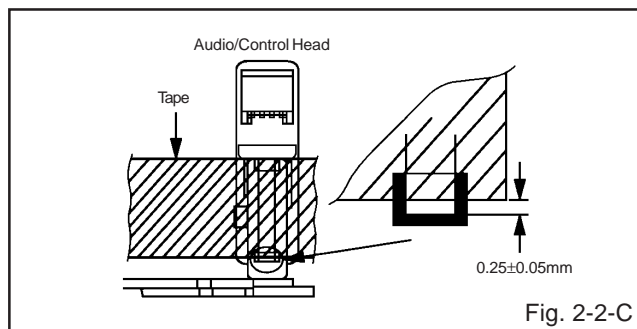
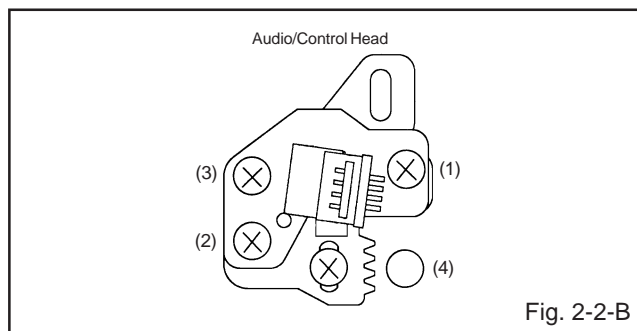
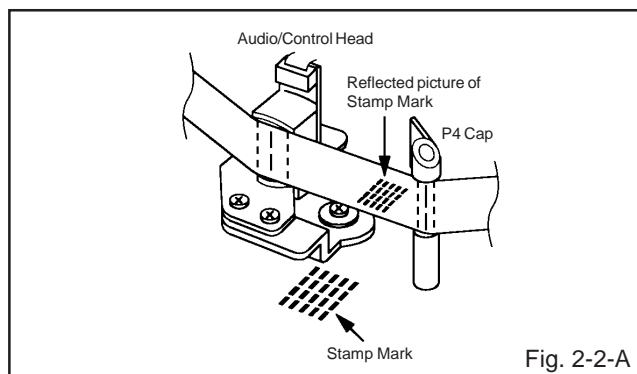

2-3: TAPE RUNNING ADJUSTMENT (X VALUE ADJUSTMENT)

1. Confirm and adjust the height of the Reel Disk. (Refer to item 1-1)
2. Confirm and adjust the position of the Tension Post. (Refer to item 1-2)
3. Adjust the Guide Roller. (Refer to item 2-1)
4. Confirm and adjust the Audio/Control Head. (Refer to item 2-2)
5. Connect CH-1 of the oscilloscope to **TP1002**, CH-2 to **TP4001** and CH-3 to **HOT side of JG180 Audio Out Jack**.
6. Playback the VHS Alignment Tape (**JG001S or JG001T**). (Refer to **SERVICING FIXTURE AND TOOLS**)
7. Press and hold the ATR button on the remote control more than 2 seconds to set tracking to center.
8. Set the X Value adjustment driver (**JG153**) to the (4) of **Fig. 2-2-B**. Adjust X value so that the envelope waveform output becomes maximum. Check if the relation between Audio and Envelope waveform becomes (1) or (2) of **Fig. 2-3**.

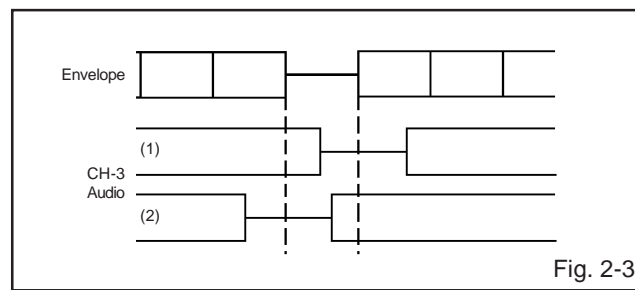

2-4: CONFIRM HI-FI AUDIO (Hi-Fi model only)

1. Connect CH-1 of the oscilloscope to **TP4001** and CH-2 to the **Hi-Fi Audio Out Jack**.
2. Playback the VHS Alignment Tape (**JG001P or JG001Q**). (Refer to **SERVICING FIXTURE AND TOOLS**)
3. Press and hold the ATR button on the remote control more than 2 seconds to set tracking to center.
4. Press the Tracking Up button and count number of steps which the audio output is changed from Hi-Fi (10KHz) to MONO (6KHz).
5. Press and hold the Tracking-Auto button on the remote control more than 2 seconds to set tracking to center.
6. Press the Tracking Down button and count number of steps which the audio output is changed from Hi-Fi (10KHz) to MONO (6KHz).
7. If the difference are more than 3 steps, set the X Value adjustment driver (**JG153**) to (4) of **Fig. 2-2-B**. Change the X Value and adjust it so that the value becomes within 2 steps.

MECHANICAL ADJUSTMENTS

3. MECHANISM ADJUSTMENT PARTS LOCATION GUIDE

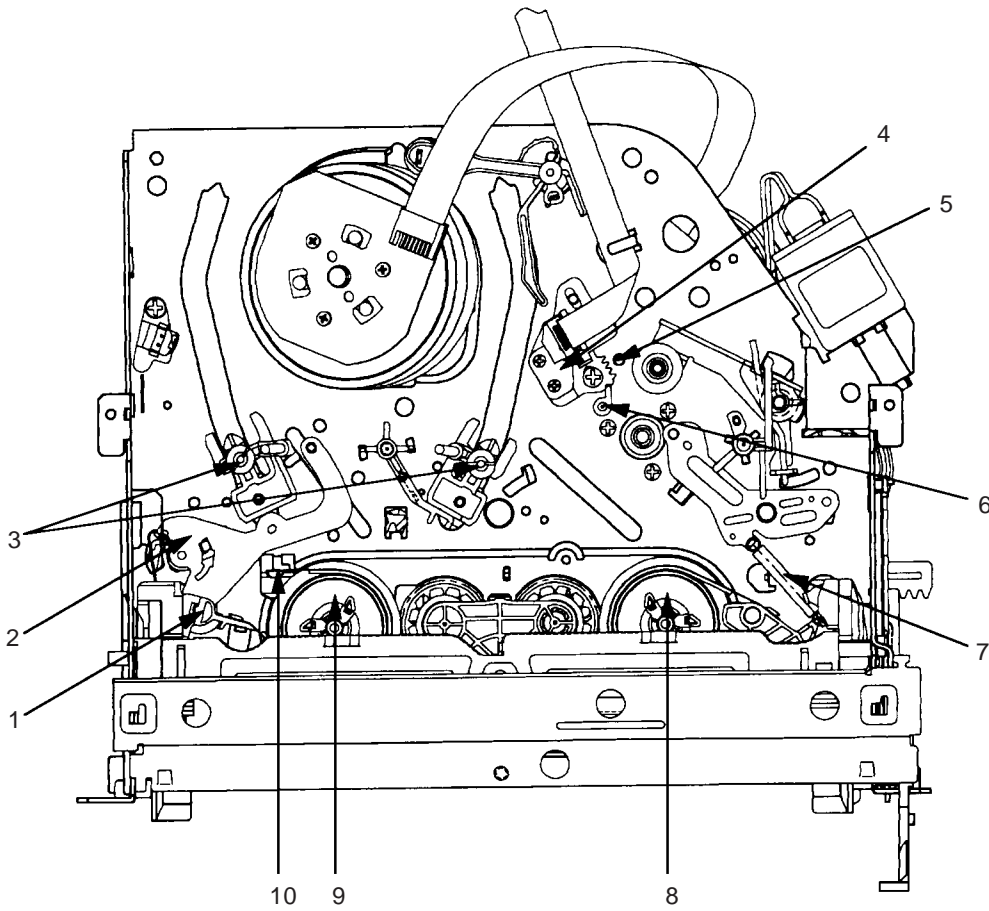

- | | |
|-----------------------------------|--|
| 1. Tension Connect | 6. P4 Post |
| 2. Tension Arm | 7. T Brake Spring |
| 3. Guide Roller | 8. T Reel |
| 4. Audio/Control Head | 9. S Reel |
| 5. X value adjustment driver hole | 10. Adjusting section for the Tension Arm position |

ELECTRICAL ADJUSTMENTS

1. BEFORE MAKING ELECTRICAL ADJUSTMENTS

Read and perform these adjustments when repairing the circuits or replacing electrical parts or PCB assemblies.

CAUTION

- Use an isolation transformer when performing any service on this chassis.
- Before removing the anode cap, discharge electricity because it contains high voltage.
- When removing a PCB or related component, after unfastening or changing a wire, be sure to put the wire back in its original position.
- When you exchange IC and Transistor for a heat sink, apply the silicon grease on the contact section of the heat sink. Before applying new silicon grease, remove all the old silicon grease. (Old grease may cause damages to the IC and Transistor.)

Prepare the following measurement tools for electrical adjustments.

1. Oscilloscope
2. Digital Voltmeter
3. Pattern Generator

On-Screen Display Adjustment

1. Unplug the AC plug for more than 5 seconds to set the clock to the non-setting state. Then, set the volume level to minimum.
2. Press the VOL. DOWN button on the set and the Channel button (9) on the remote control simultaneously to appear the adjustment mode on the screen as shown in Fig. 1-1.

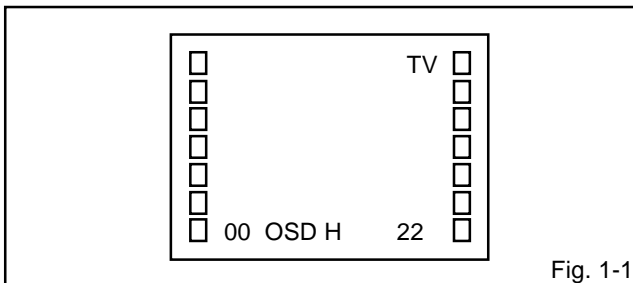

Fig. 1-1

3. Use the Channel UP/DOWN button or Channel button (0-9) on the remote control to select the options shown in Fig. 1-2.
4. Press the MENU button on the remote control to end the adjustments.

NO.	FUNCTION	NO.	FUNCTION
00	OSD H	16	CONT.CENT
01	CUT OFF	17	CONT.MAX
02	RF AGC	18	CONT.MIN
03	V.VCO	19	COL.CENT
04	H.VCO	20	COL.MAX
05	H.PHAS	21	COL.MIN
06	V.SIZE	22	TINT
07	V.SFT	23	SHARP
08	R.DRV	24	FM.LVL
09	B.DRV	25	LVL
10	R CUT OFF	26	SEP1
11	G CUT OFF	27	SEP2
12	B CUT OFF	28	T.MONO
13	BRI.CENT	29	T.STE
14	BRI.MAX		
15	BRI.MIN		

Fig. 1-2

2. BASIC ADJUSTMENTS (VCR SECTION)

2-1: PG SHIFTER

1. Connect the connector of AV Jack Jig (JG180) to CP1003.
2. Connect CH-1 on the oscilloscope to TP1002 and CH-2 to HOT side of JG180 Video Out Jack.
3. Playback the alignment tape.
4. Press both VOL.DOWN button on the set and the Channel button (5) on the remote control simultaneously to set tracking to center.
5. Press the VOL. DOWN button on the set and the channel button (3) on the remote control simultaneously until the indicator REC disappears. If the indicator REC disappears, adjustment is completed.

(If the above adjustments doesn't work well:)

6. Press the VOL. DOWN button on the set and the channel button (3) on the remote control simultaneously until the indicator REC disappears.
7. When the REC indicator is blinking, press both VOL. DOWN button on the set and the channel button (4) on the remote control simultaneously and adjust the Tracking +/- button until the arising to the down of Head Switching Pulse becomes $6.5 \pm 0.5H$. (Refer to Fig. 2-1-A, B)
8. Press the Tracking Auto button.

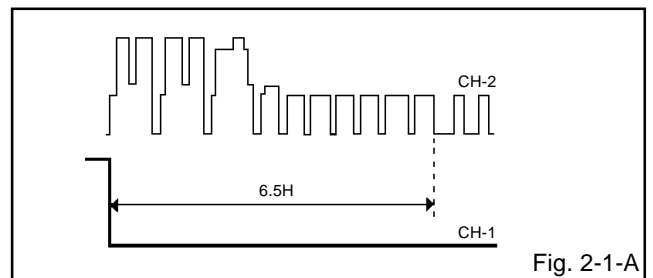

Fig. 2-1-A

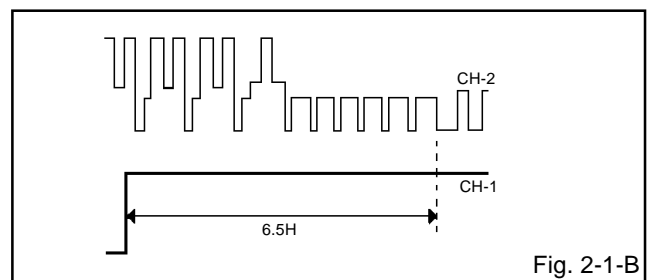

Fig. 2-1-B

2-2: VCO FREERUN

1. Receive the VHF HIGH ($63 \pm 1dB$).
2. Place the set with Aging Test for more than 10 minutes.
3. Connect the digital voltmeter between the pin 5 of CP351 and the pin 1 (GND) of CP351.
4. Activate the adjustment mode display of Fig. 1-1 and press the channel button (03) on the remote control to select "V.VCO".
5. Press the VOL. UP/DOWN button on the remote control until the digital voltmeter is 2.5V.
6. After the 2.5V adjustment, countdown the VIF VCO step No. by 1 step with the VOL. DOWN button.

ELECTRICAL ADJUSTMENTS

2-3: RF AGC

1. Receive the VHF HIGH (63 ± 1 dB).
2. Connect the digital voltmeter between the **pin 5 of CP351** and the **pin 1 (GND) of CP351**.
3. Activate the adjustment mode display of **Fig. 1-1** and press the channel button (**02**) on the remote control to select "RF AGC".
4. Press the VOL. UP/DOWN button on the remote control until the digital voltmeter is 2.7 ± 0.05 V.

(TV SECTION)

2-4: CONSTANT VOLTAGE

1. Using the remote control, set the brightness and contrast to normal position.
2. Connect the digital voltmeter to **FH504**.
3. Set condition is AV MODE without signal.
4. Adjust the **VR502** until the digital voltage is 135 ± 0.5 V.

2-5: CUT OFF

1. Adjust the unit to the following settings.
R CUT OFF=127, G CUT OFF=127, B CUT OFF=127,
SUB BRI.CENT=127, SUB CONT.MAX=100.
2. Place the set with Aging Test for more than 15 minutes.
3. Set condition is AV MODE without signal.
4. Using the remote control, set the brightness and contrast to normal position.
5. Activate the adjustment mode display of **Fig. 1-1** and press the channel button (**01**) on the remote control to select "CUT OFF".
6. Adjust the **Screen Volume** until a dim raster is obtained.

2-6: WHITE BALANCE

NOTE: Adjust after performing CUT OFF adjustment.

1. Place the set with Aging Test for more than 15 minutes.
2. Receive the color bar pattern.
3. Using the remote control, set the brightness and contrast to normal position.
4. Activate the adjustment mode display of **Fig. 1-1** and press the channel button (**10**) on the remote control to select "R CUT OFF".
5. Using the VOL. UP/DOWN button on the remote control, adjust the R CUT OFF.
6. Press the CH. UP/DOWN button on the remote control to select the "R DRIVE", "B DRIVE", "G CUT OFF" or "B CUT OFF".
7. Using the VOL. UP/DOWN button on the remote control, adjust the R DRIVE, B DRIVE, G CUT OFF or B CUT OFF.
8. Perform the above adjustments 6 and 7 until the white color is looked like a white.

2-7: FOCUS

1. Receive the monoscope pattern.
2. Using the remote control, set the brightness and contrast to normal position.
3. Turn the Focus Volume fully counterclockwise once.
4. Adjust the **Focus Volume** until picture is distinct.

2-8: HORIZONTAL PHASE

1. Receive the monoscope pattern.
2. Using the remote control, set the brightness and contrast to normal position.
3. Activate the adjustment mode display of **Fig. 1-1** and press the channel button (**05**) on the remote control to select "H PHAS".
4. Press the VOL. UP/DOWN button on the remote control until the SHIFT quantity of the OVER SCAN on right and left becomes minimum.

2-9: VERTICAL SHIFT

1. Receive the monoscope pattern.
2. Using the remote control, set the brightness and contrast to normal position.
3. Activate the adjustment mode display of **Fig. 1-1** and press the channel button (**07**) on the remote control to select "V SFT".
4. Check if the step No. V. SHIFT is "3".
5. Adjust the **VR401** until the horizontal line becomes fit to the notch of the shadow mask.

2-10: VERTICAL SIZE

1. Receive the monoscope pattern.
2. Using the remote control, set the brightness and contrast to normal position.
3. Activate the adjustment mode display of **Fig. 1-1** and press the channel button (**06**) on the remote control to select "V SIZE".
4. Press the VOL. UP/DOWN button on the remote control until the SHIFT quantity of the OVER SCAN on upside and downside becomes $10 \pm 2\%$.

2-11: SUB BRIGHTNESS

1. Receive the monoscope pattern. (RF Input)
2. Using the remote control, set the brightness and contrast to normal position.
3. Activate the adjustment mode display of **Fig. 1-1** and press the channel button (**13**) on the remote control to select "BRI.CENT".
4. Press the VOL.UP/DOWN button on the remote control until the screen begin to shine.
5. Receive a broadcast and check if the picture is normal.
6. Receive the monoscope pattern. (Audio Video Input)
7. Press the INPUT SELECT button on the remote control to set to the AV mode. Then perform the above adjustments 2~5.

2-12: SUB CONTRAST MAX

1. Activate the adjustment mode display of **Fig. 1-1** and press the channel button (**17**) on the remote control to select "CONT.MAX".
2. Press the VOL. UP/DOWN button on the remote control until the contrast step No. becomes "65".
3. Receive a broadcast and check if the picture is normal.
4. Press the INPUT SELECT button on the remote control to set to the AV mode. Then perform the above adjustments 1~3.

ELECTRICAL ADJUSTMENTS

2-13: SUB TINT

1. Receive the color bar pattern. (RF Input)
2. Using the remote control, set the brightness, contrast, color and tint to normal position.
3. Connect the oscilloscope to **TP801**.
4. Activate the adjustment mode display of **Fig. 1-1** and press the channel button (**22**) on the remote control to select "TINT".
5. Press the VOL. UP/DOWN button on the remote control until the section "A" becomes a straight line. (**Refer to Fig. 2-2**)
6. Receive the color bar pattern. (Audio Video Input)
7. Press the INPUT SELECT button on the remote control to set to the AV mode. Then perform the above adjustments 2~5.

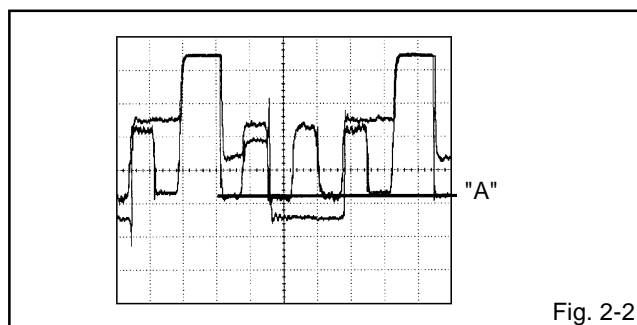

Fig. 2-2

2-14: SUB COLOR

1. Receive the color bar pattern. (RF Input)
2. Using the remote control, set the brightness, contrast, color and tint to normal position.
3. Connect the oscilloscope to **TP803**.
4. Activate the adjustment mode display of **Fig. 1-1** and press the channel button (**19**) on the remote control to select "COL.CENT".
5. Adjust the VOLTS RANGE VARIABLE knob of the oscilloscope until the range between white 100% and 0% is set to 4 scales on the screen of the oscilloscope.
6. Press the VOL. UP/DOWN button on the remote control until the red color level is adjusted to $110 \pm 10\%$ of the white level. (**Refer to Fig. 2-3**)
7. Receive the color bar pattern. (Audio Video Input)
8. Press the INPUT SELECT button on the remote control to set to the AV mode. Then perform the above adjustments 2~6.

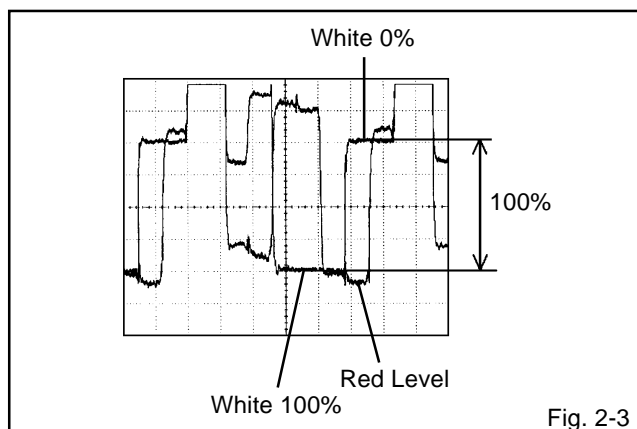

Fig. 2-3

2-15: OSD HORIZONTAL

1. Activate the adjustment mode display of **Fig. 1-1**.
2. Press the VOL. UP/DOWN button on the remote control until the difference of A and B becomes minimum. (**Refer to Fig. 2-4**)

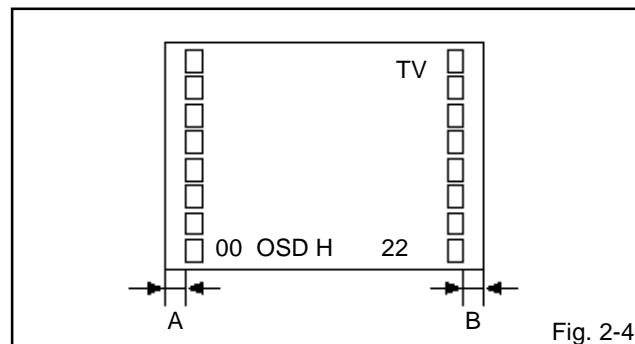

Fig. 2-4

2-16: SUB SHARPNESS

1. Activate the adjustment mode display of **Fig. 1-1** and press the channel button (**23**) on the remote control to select "SHARP".
2. Check if the step No. of SHARPNESS is "35".
3. Press the INPUT SELECT button on the remote control to set to the AV mode. Then perform the above adjustments 1, 2.

2-17: H VCO

1. Activate the adjustment mode display of **Fig. 1-1** and press the channel button (**04**) on the remote control to select "H VCO".
2. Check if the step No. of H VCO is "4".

ELECTRICAL ADJUSTMENTS

3. PURITY AND CONVERGENCE ADJUSTMENTS

NOTE

1. Turn the unit on and let it warm up for at least 30 minutes before performing the following adjustments.
2. Place the CRT surface facing east or west to reduce the terrestrial magnetism.
3. Turn ON the unit and demagnetize with a Degauss Coil.

3-1: STATIC CONVERGENCE (ROUGH ADJUSTMENT)

1. Tighten the screw for the magnet. Refer to the adjusted CRT for the position. **(Refer to Fig. 3-1)**
If the deflection yoke and magnet are in one body, untighten the screw for the body.
2. Receive the green raster pattern from the color bar generator.
3. Slide the deflection yoke until it touches the funnel side of the CRT.
4. Adjust center of screen to green, with red and blue on the sides, using the pair of purity magnets.
5. Switch the color bar generator from the green raster pattern to the crosshatch pattern.
6. Combine red and blue of the 3 color crosshatch pattern on the center of the screen by adjusting the pair of 4 pole magnets.
7. Combine red/blue (magenta) and green by adjusting the pair of 6 pole magnets.
8. Adjust the crosshatch pattern to change to white by repeating steps 6 and 7.

3-2: PURITY

NOTE

Adjust after performing adjustments in section 3-1.

1. Receive the green raster pattern from color bar generator.
2. Adjust the pair of purity magnets to center the color on the screen.
Adjust the pair of purity magnets so the color at the ends are equally wide.
3. Move the deflection yoke backward (to neck side) slowly, and stop it at the position when the whole screen is green.
4. Confirm red and blue colors.
5. Adjust the slant of the deflection yoke while watching the screen, then tighten the fixing screw.

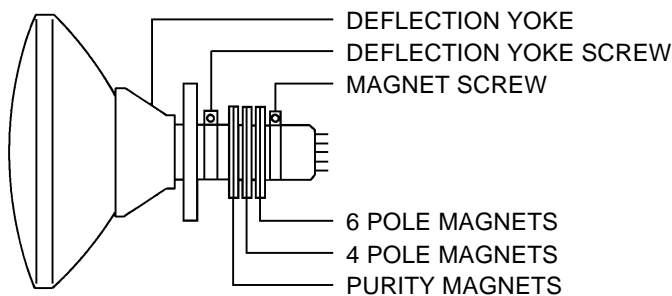

Fig. 3-1

3-3: STATIC CONVERGENCE

NOTE

Adjust after performing adjustments in section 3-2.

1. Receive the crosshatch pattern from the color bar generator.
2. Combine red and blue of the 3 color crosshatch pattern on the center of the screen by adjusting the pair of 4 pole magnets.
3. Combine red/blue (magenta) and green by adjusting the pair of 6 pole magnets.

3-4: DYNAMIC CONVERGENCE

NOTE

Adjust after performing adjustments in section 3-3.

1. Adjust the differences around the screen by moving the deflection yoke upward/downward and right/left. **(Refer to Fig. 3-2-a)**
2. Insert three wedges between the deflection yoke and CRT funnel to fix the deflection yoke. **(Refer to Fig. 3-2-b)**

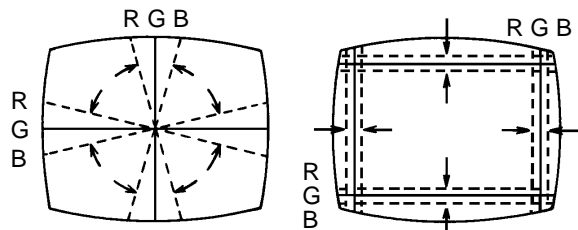

UPWARD/DOWNWARD SLANT RIGHT/LEFT SLANT

Fig. 3-2-a

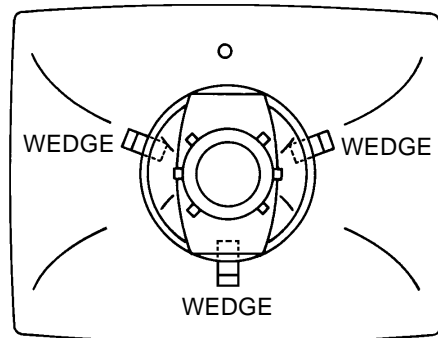

WEDGE POSITION

Fig. 3-2-b

ELECTRICAL ADJUSTMENTS

4. ELECTRICAL ADJUSTMENT PARTS LOCATION GUIDE (WIRING CONNECTION)

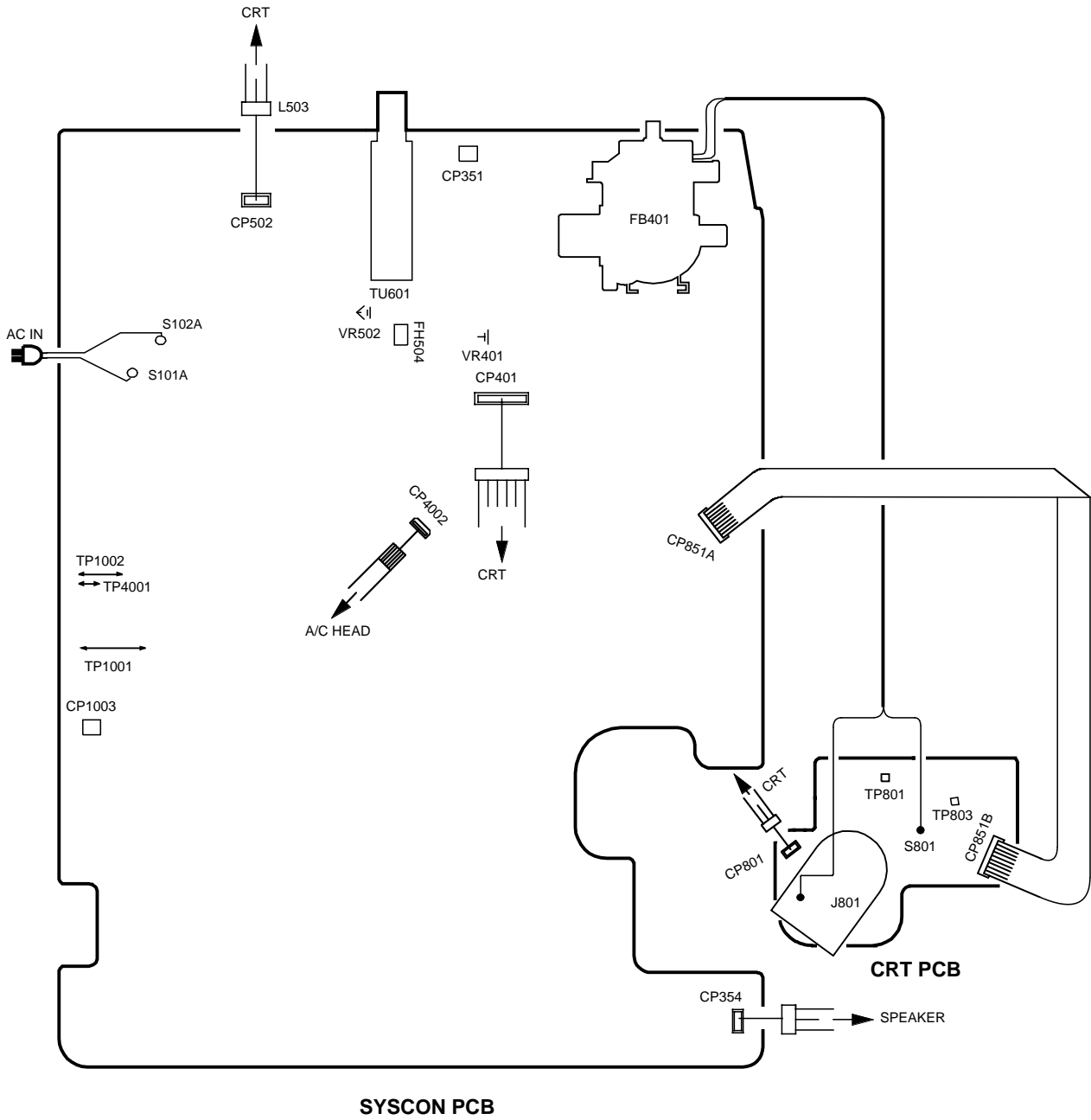

TV BLOCK DIAGRAM

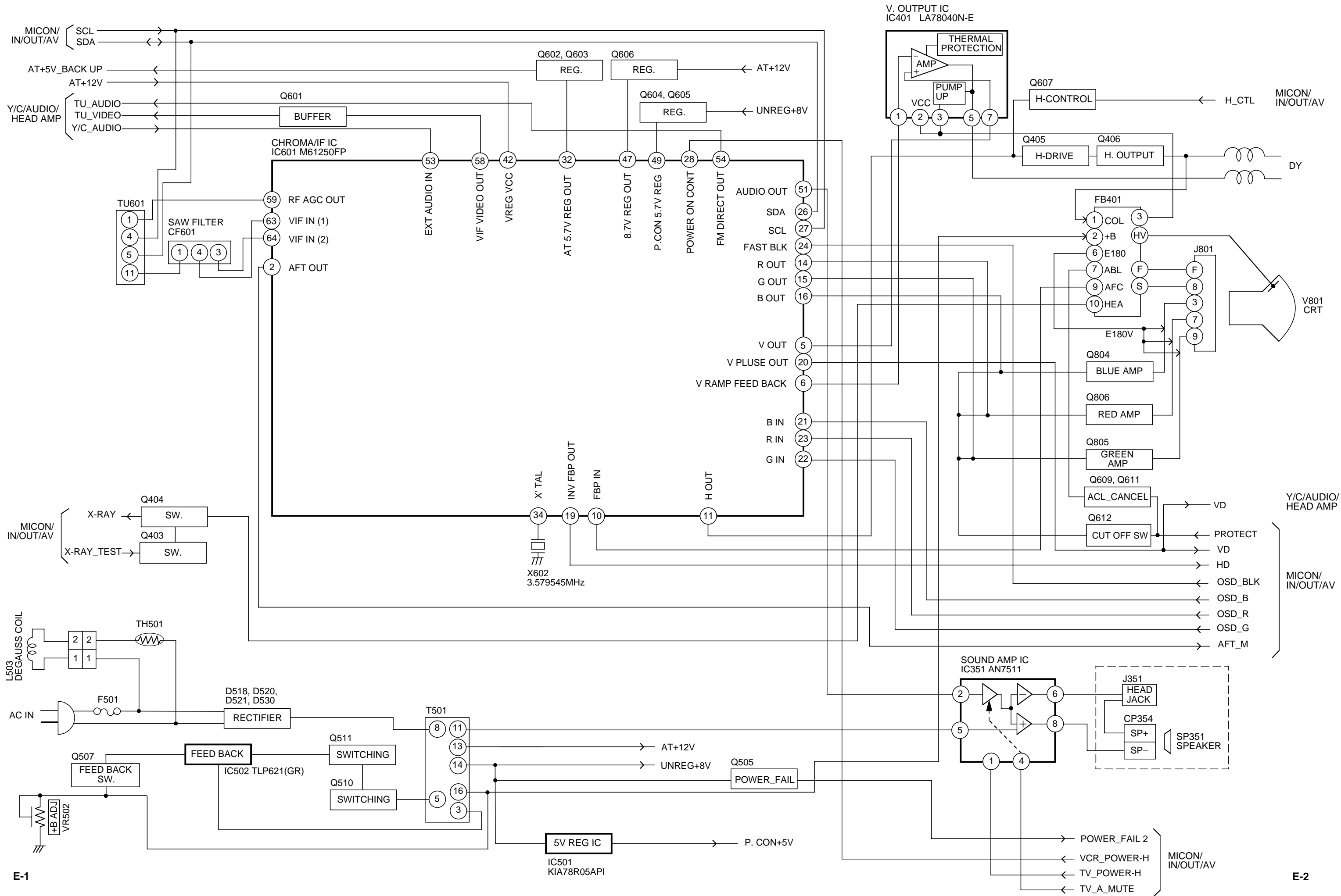

Y/C/AUDIO/HEAD AMP BLOCK DIAGRAM

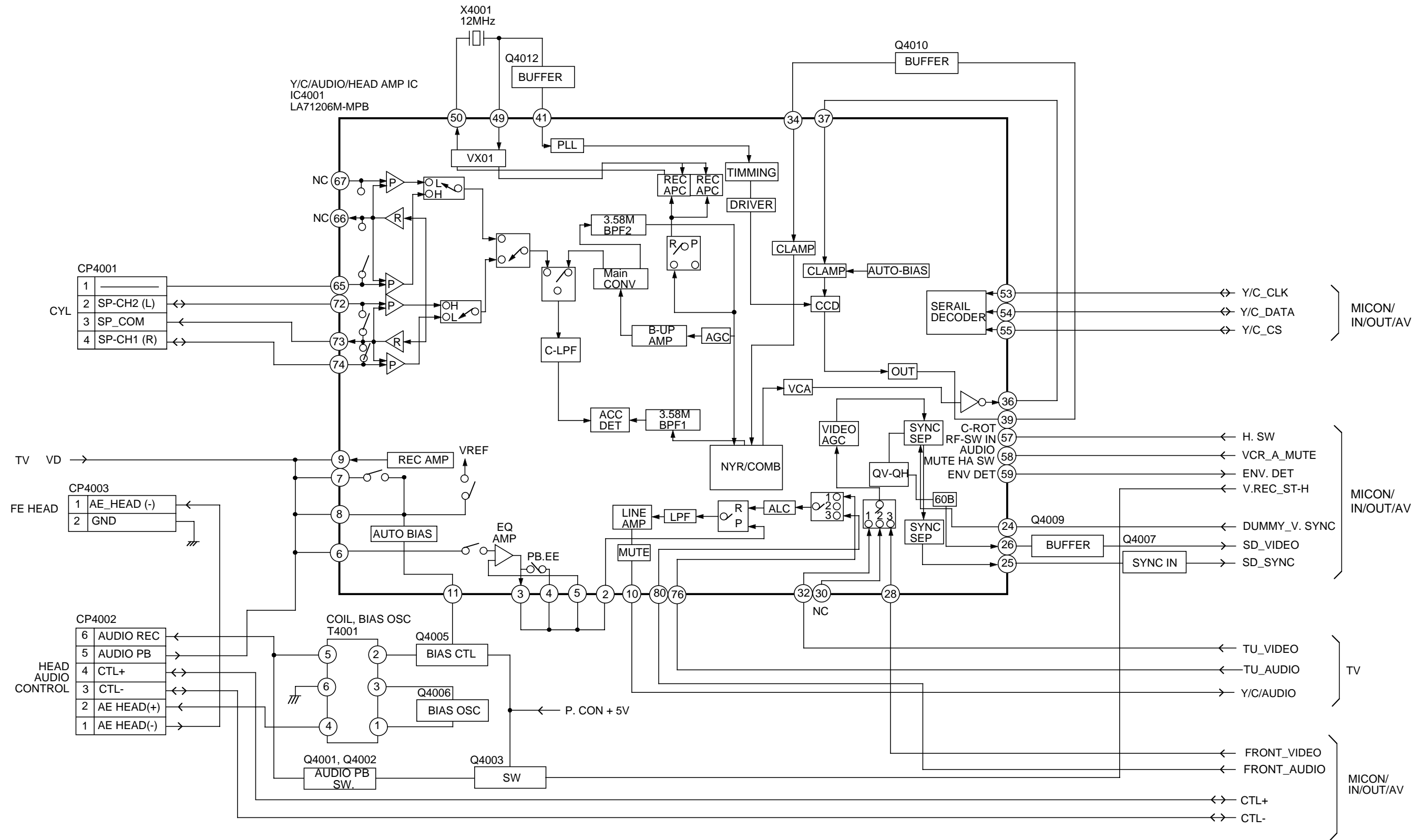

MICON/IN/OUT/AV BLOCK DIAGRAM

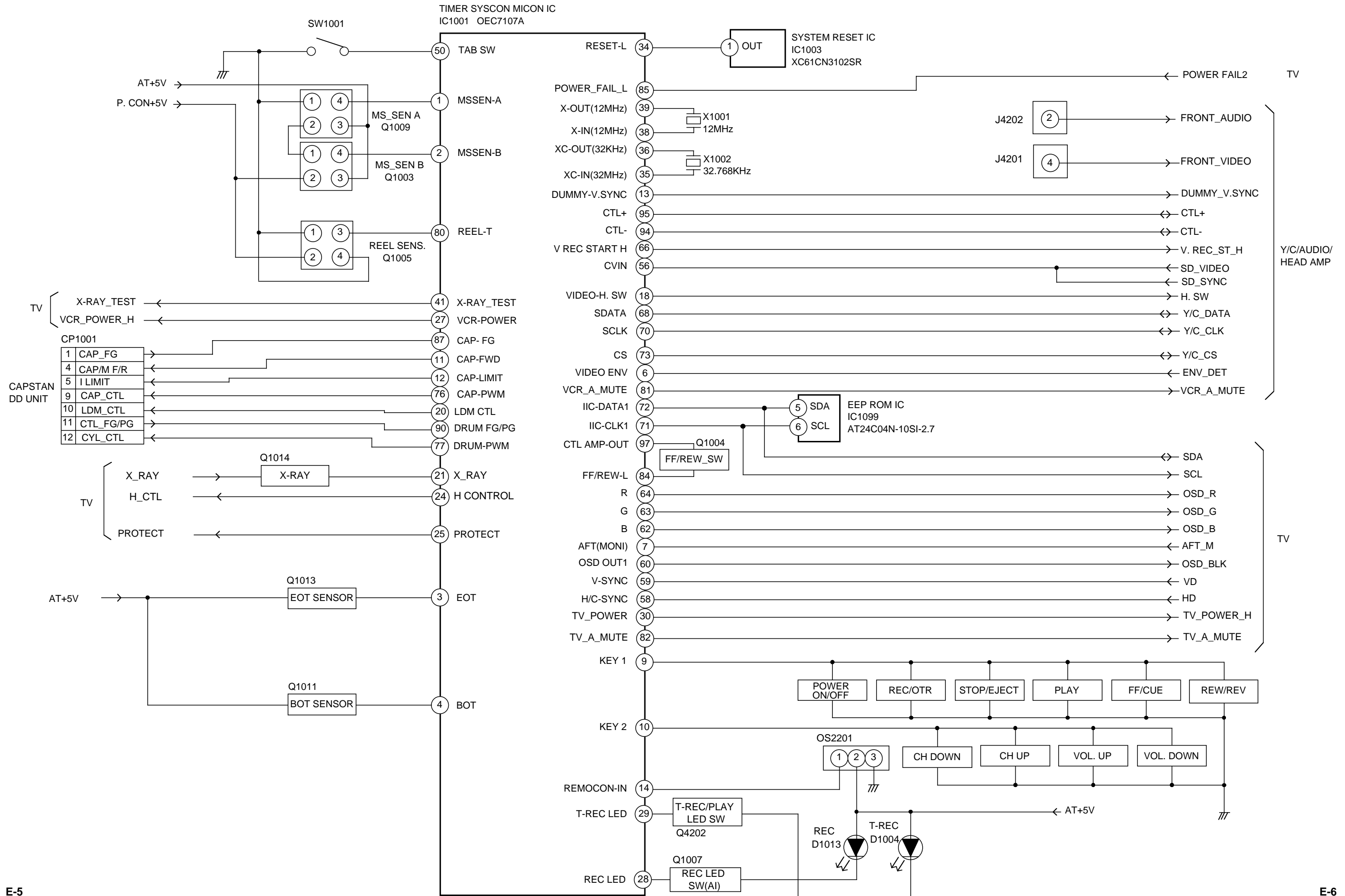

PRINTED CIRCUIT BOARDS
SYSCON/CRT (INSERTED PARTS)
SOLDER SIDE

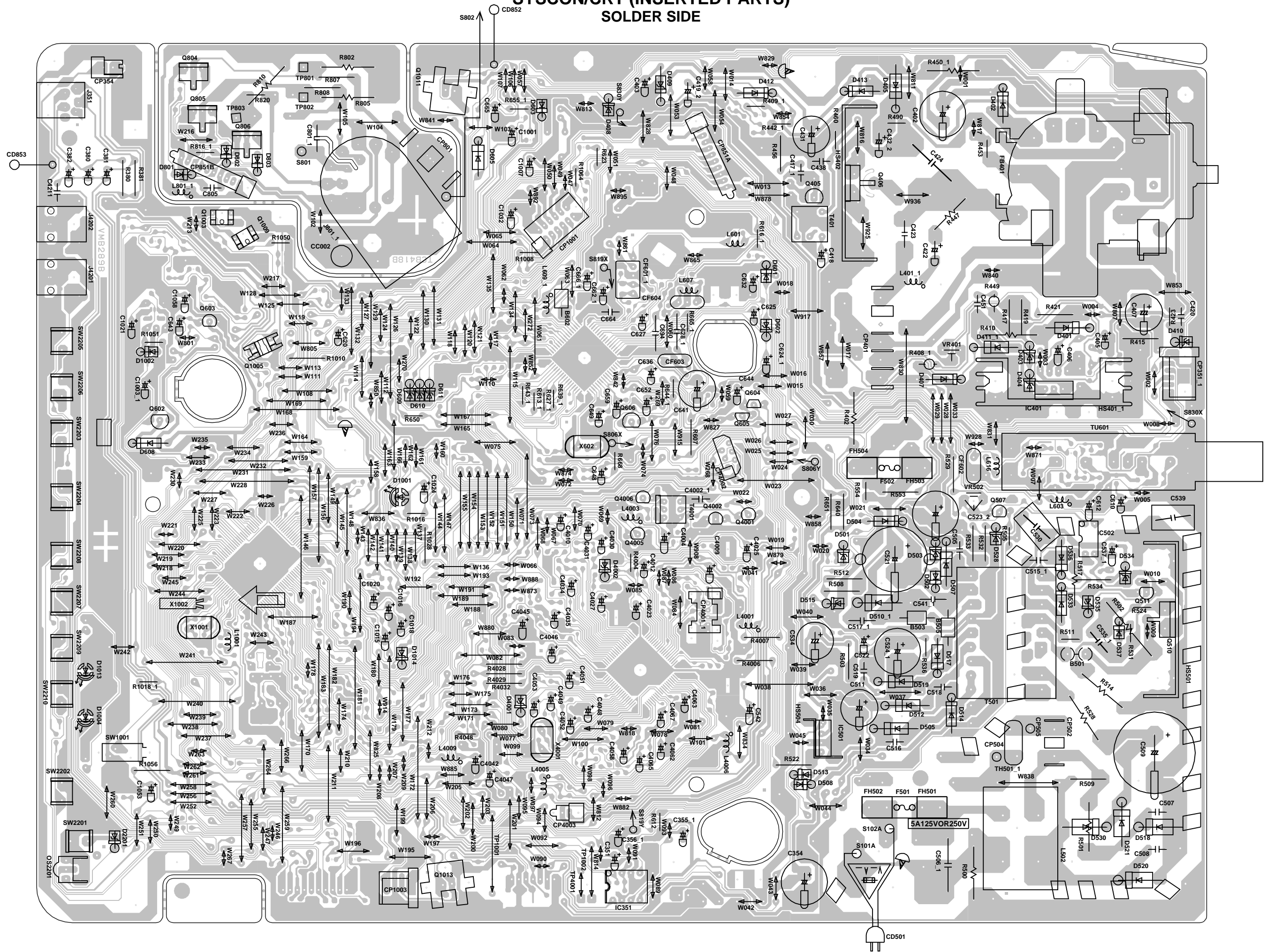

Y/C/AUDIO/HEAD AMP SCHEMATIC DIAGRAM (SYSCON PCB)

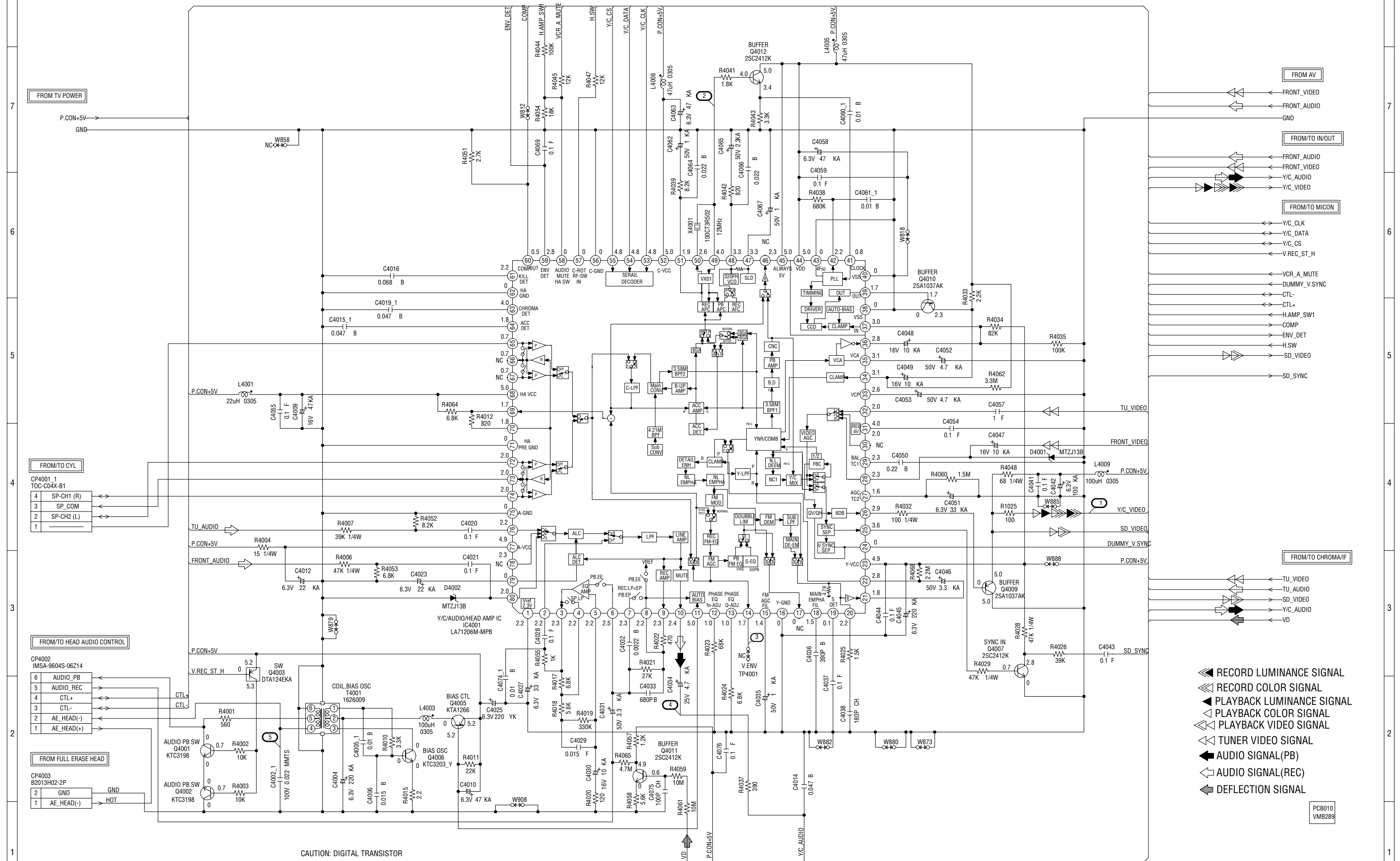

- ◀ RECORD LUMINANCE SIGNAL
- ◀ RECORD COLOR SIGNAL
- ▶ PLAYBACK LUMINANCE SIGNAL
- ▶ PLAYBACK COLOR SIGNAL
- ▶ PLAYBACK VIDEO SIGNAL
- ▶ TUNER VIDEO SIGNAL
- ▶ AUDIO SIGNAL (PB)
- ▶ AUDIO SIGNAL (REC)
- ▶ DEFLECTION SIGNAL

CAUTION: DIGITAL TRANSISTOR

NOTE: THE DC VOLTAGE EACH PART WAS MEASURED WITH THE DIGITAL TESTER DURING PLAYBACK.

NOTE: THIS SCHEMATIC DIAGRAM IS THE LATEST AT THE TIME OF PRINTING AND SUBJECT TO CHANGE WITHOUT NOTICE.

MICON SCHEMATIC DIAGRAM (SYSCON PCB)

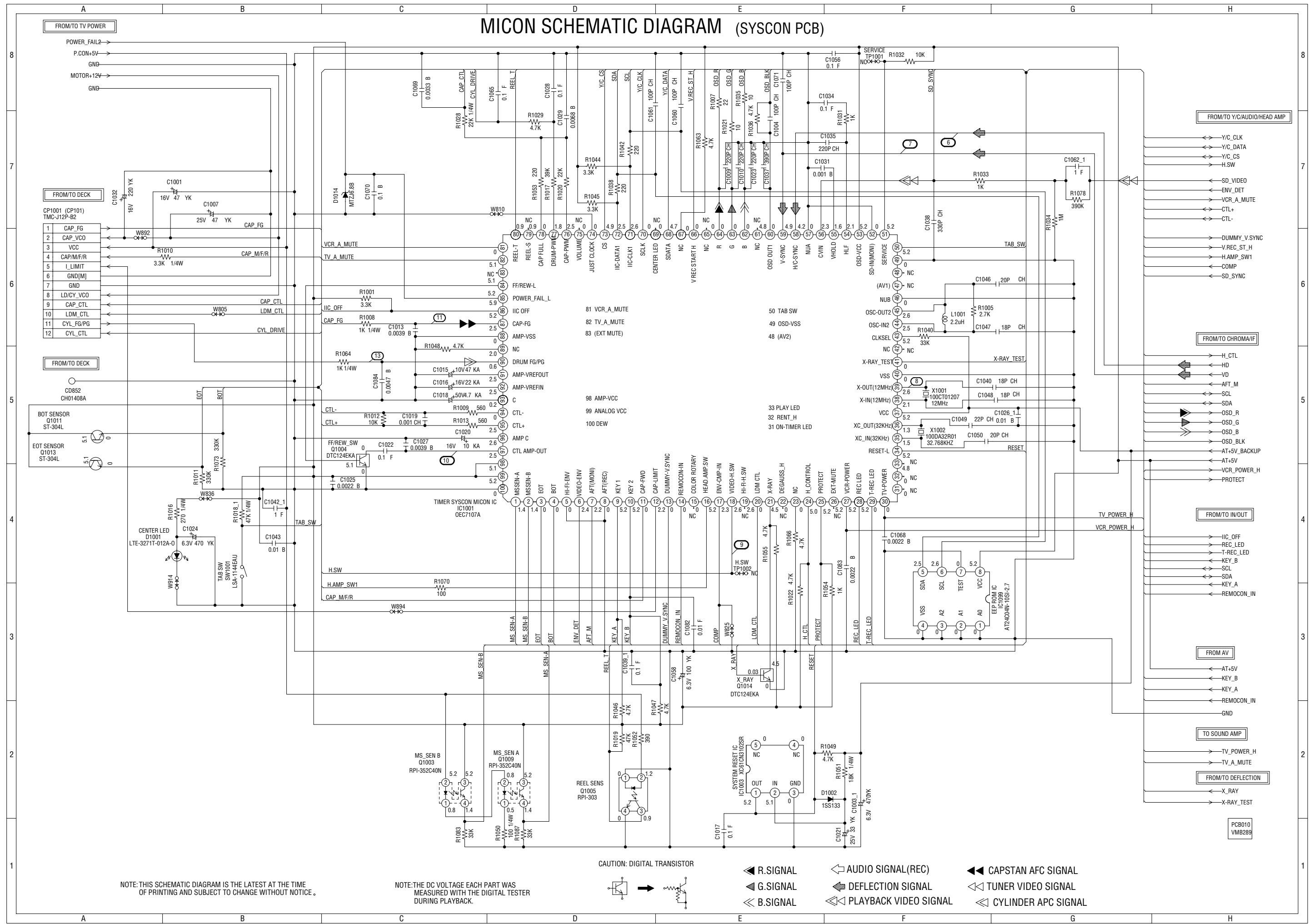

NOTE: THIS SCHEMATIC DIAGRAM IS THE LATEST AT THE TIME OF PRINTING AND SUBJECT TO CHANGE WITHOUT NOTICE.

NOTE: THE DC VOLTAGE EACH PART WAS MEASURED WITH THE DIGITAL TESTER DURING PLAYBACK.

CAUTION: DIGITAL TRANSISTOR

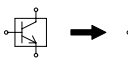

- ▶ R.SIGNAL
- ▶ G.SIGNAL
- ▶ B.SIGNAL
- ◀ AUDIO SIGNAL(REC)
- ◀ DEFLECTION SIGNAL
- ◀ PLAYBACK VIDEO SIGNAL
- ◀ CAPSTAN AFC SIGNAL
- ◀ TUNER VIDEO SIGNAL
- ◀ CYLINDER APC SIGNAL

AV SCHEMATIC DIAGRAM (AV PCB)

TO Y/C/AUDIO/HEAD AMP

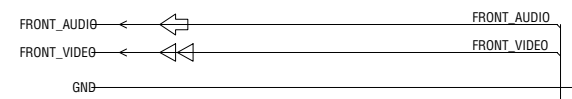

TO IN/OUT

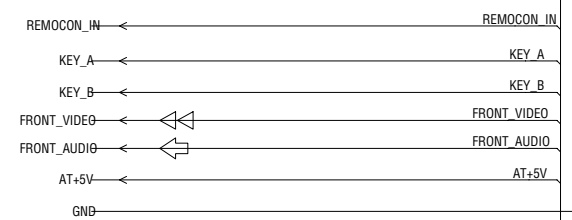

FROM/TO SOUND AMP

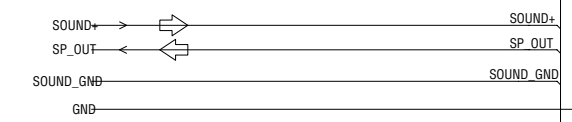

TO MICON

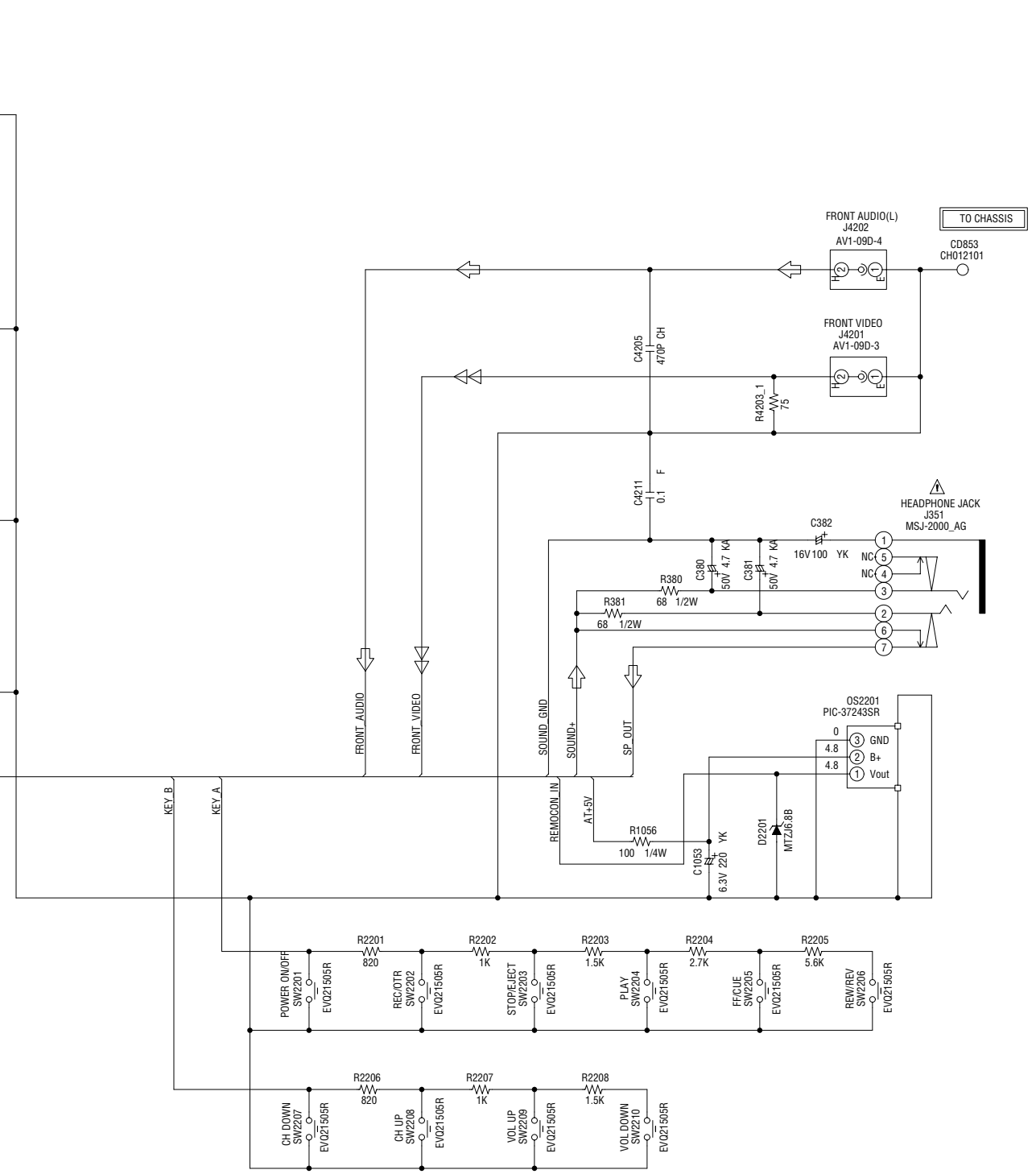
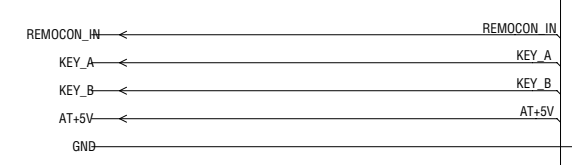

CAUTION SINCE THESE PARTS MARKED BY ARE CRITICAL FOR SAFETY, USE ONES DESCRIBED IN PARTS LIST ONLY.

ATTENTION LES PIECES REPARÉES PAR UN ÉTANT DANGEREUSES AN POINT DE VUE SECURITE N'UTILISER QUE CELLS DECRITES DANS LA NOMENCLATURE DES PIECES.

NOTE: THE DC VOLTAGE EACH PART WAS MEASURED WITH THE DIGITAL TESTER DURING PLAYBACK.

NOTE: THIS SCHEMATIC DIAGRAM IS THE LATEST AT THE TIME OF PRINTING AND SUBJECT TO CHANGE WITHOUT NOTICE.

TUNER VIDEO SIGNAL
 AUDIO SIGNAL (REC)

PCB010
VMB289

CHROMA/IF SCHEMATIC DIAGRAM(SYSCON PCB)

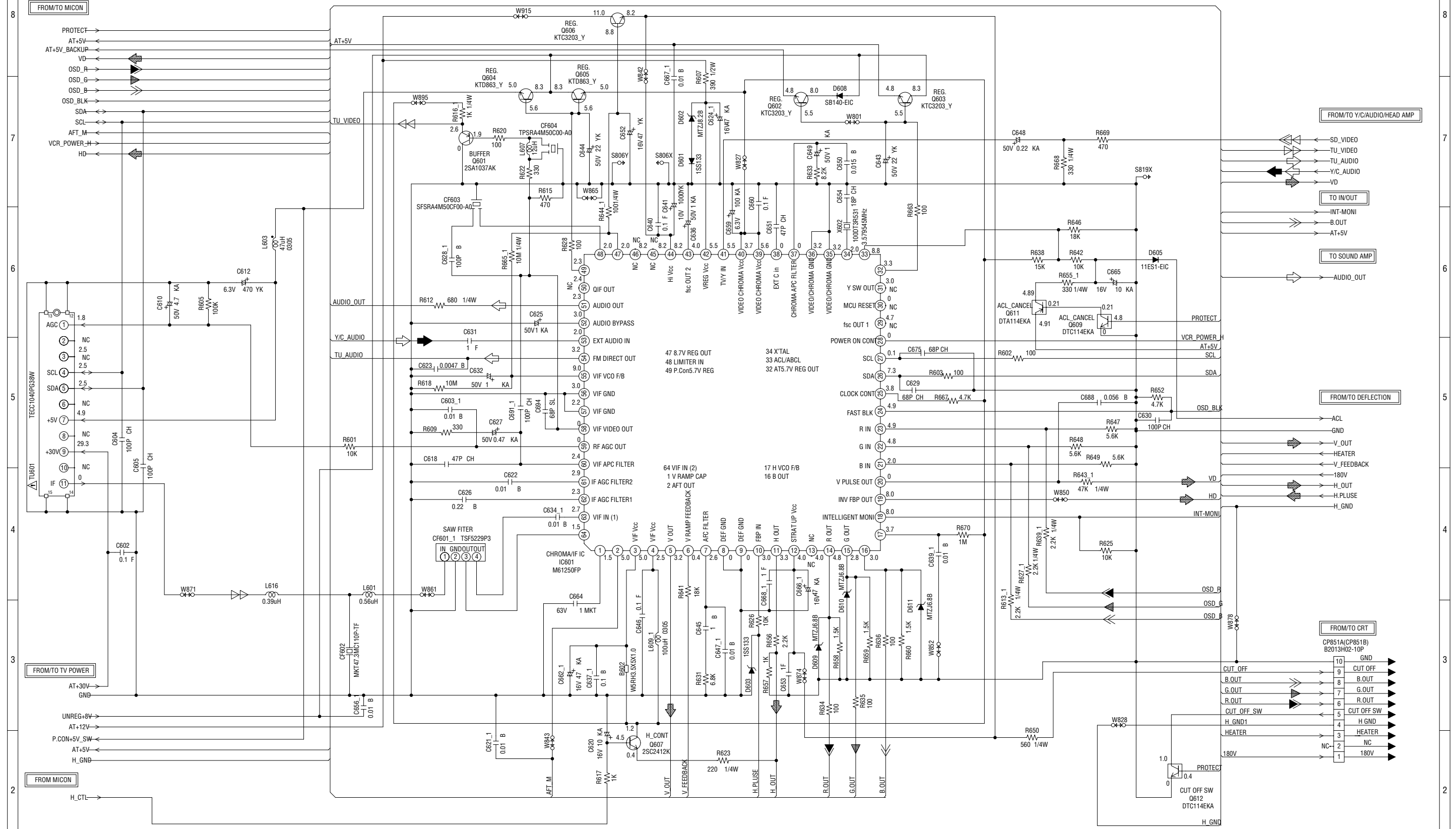

- ▶ R.SIGNAL
- ▶ G.SIGNAL
- ▶ B.SIGNAL
- ▶ AUDIO SIGNAL(PB)
- ▶ AUDIO SIGNAL(REC)
- ▶ DEFLECTION SIGNAL
- ▶ PLAYBACK VIDEO SIGNAL
- ▶ TUNER VIDEO SIGNAL

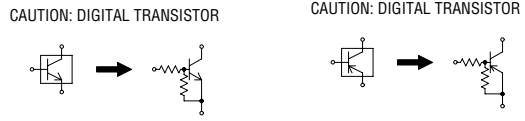

NOTE:THE DC VOLTAGE EACH PART WAS MEASURED WITH THE DIGITAL TESTER DURING PLAYBACK.

NOTE:THIS SCHEMATIC DIAGRAM IS THE LATEST AT THE TIME OF PRINTING AND SUBJECT TO CHANGE WITHOUT NOTICE.

CAUTION SINCE THESE PARTS MARKED BY ARE CRITICAL FOR SAFETY, USE ONES DESCRIBED IN PARTS LIST ONLY.

ATTENTION LES PIECES REPARÉES PAR UN ÉTANT DANGEREUSES AN POINT DE VUE SECURITE N'UTILISER QUE CELLS DECRITES DANS LA NOMENCLATURE DES PIECES.

PCB010
VMB289

SOUND AMP SCHEMATIC DIAGRAM (SYSCON PCB)

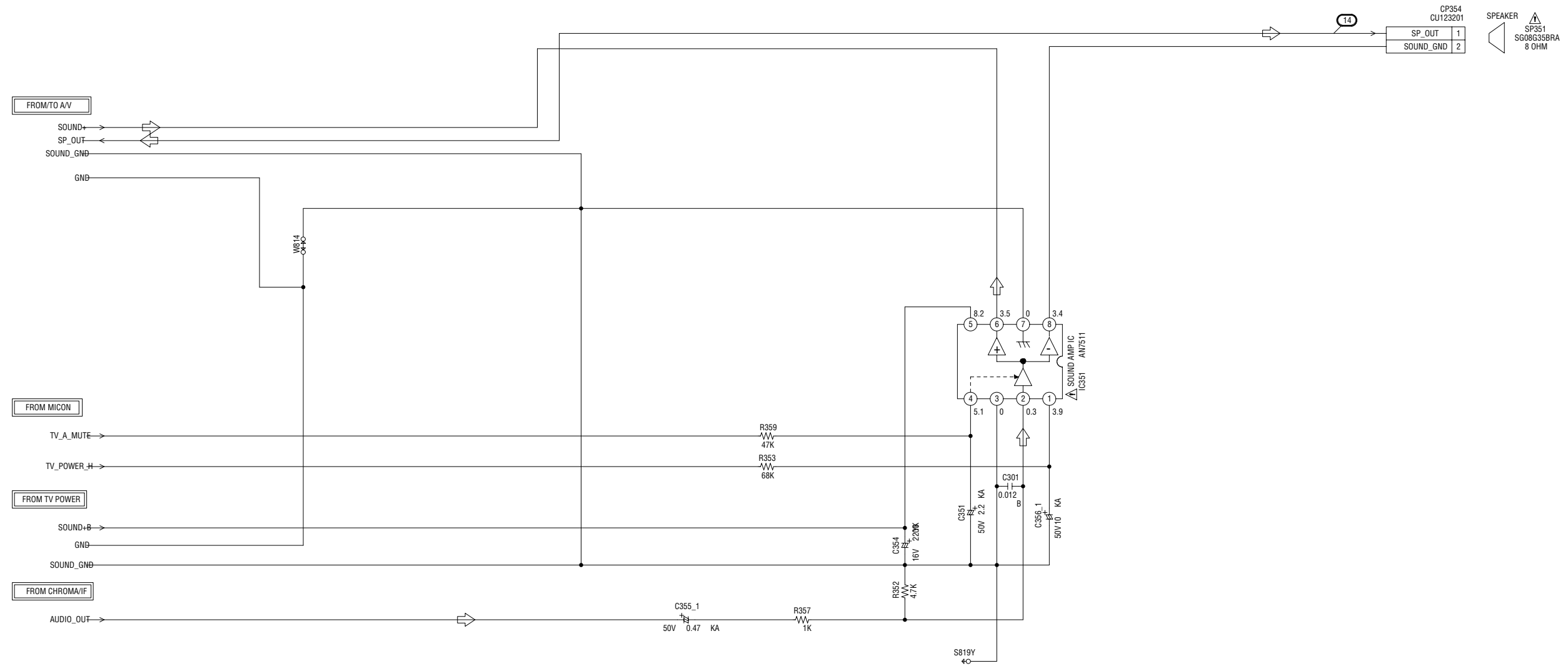

NOTE: THE DC VOLTAGE EACH PART WAS MEASURED WITH THE DIGITAL TESTER DURING PLAYBACK.

NOTE: THIS SCHEMATIC DIAGRAM IS THE LATEST AT THE TIME OF PRINTING AND SUBJECT TO CHANGE WITHOUT NOTICE.

CAUTION SINCE THESE PARTS MARKED BY ARE CRITICAL FOR SAFETY, USE ONES DESCRIBED IN PARTS LIST ONLY.

ATTENTION LES PIÈCES RÉPARÉES PAR UN ÉTANT DANGEREUSES AN POINT DE VUE SÉCURITÉ N'UTILISER QUE CELLES DÉCRITES DANS LA NOMENCLATURE DES PIÈCES.

AUDIO SIGNAL (REC)

PCB010
VMB289

TV POWER SCHEMATIC DIAGRAM (SYSCON PCB)



CAUTION: FOR CONTINUED PROTECTION AGAINST FIRE HAZARD, REPLACE ONLY WITH THE SAME TYPE FUSE 5A 125V (F501) AND 2.5A 125V (F502).

ATTENTION: POUR UNE PROTECTION CONTINUE LES RISQUES D'INCENDIE N'UTILISER QUE DES FUSIBLE DE MEME TYPE 5A 125V (F501) AND 2.5A 125V (F502).

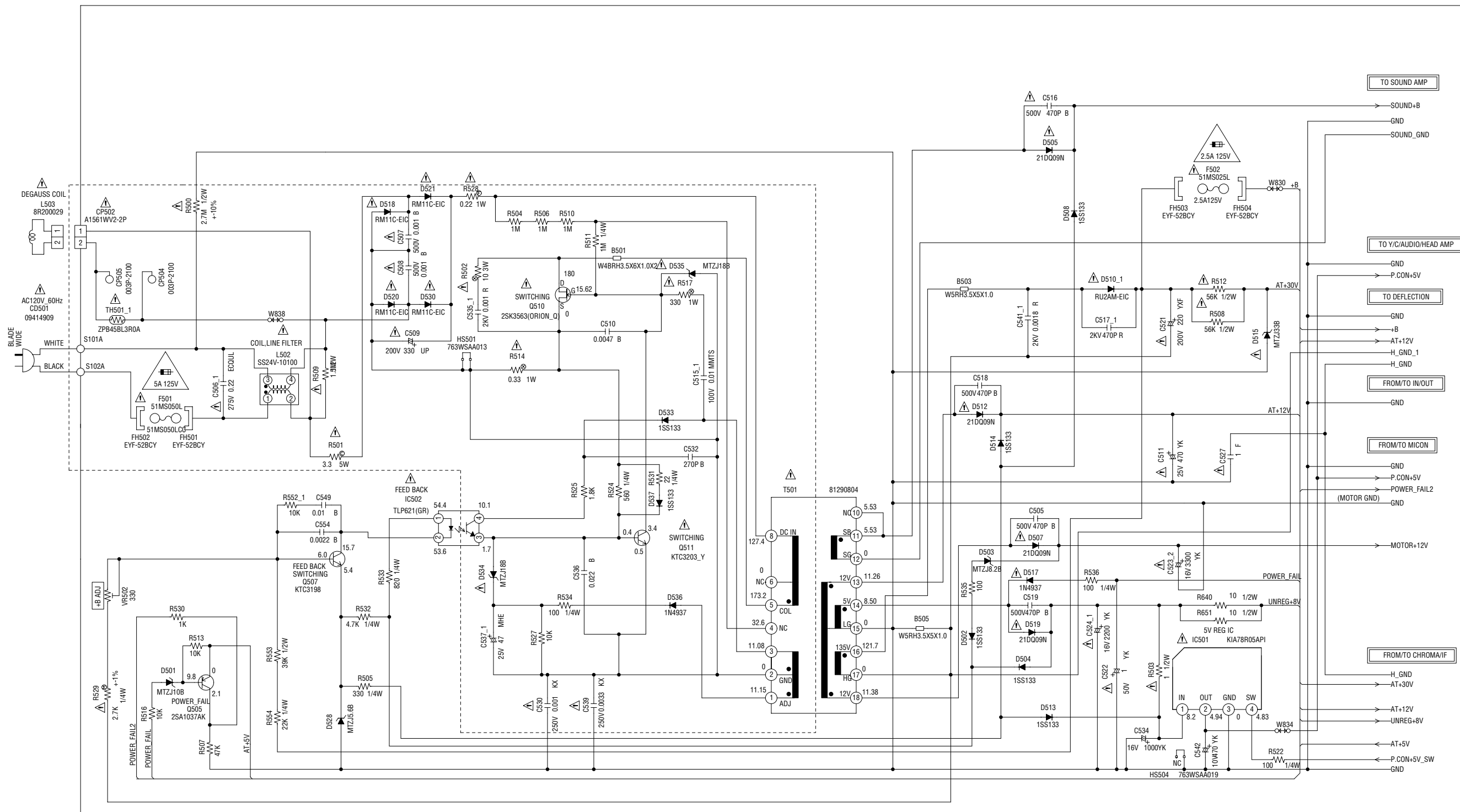

NOTE: THE RESISTOR MARKED F IS FUSE RESISTOR. THE ALUMI ELECTROLYTIC CAPACITOR MARKED NP IS NON POLAR ONE.

NOTE: THE DC VOLTAGE AT EACH PART WAS MEASURED WITH THE DIGITAL TESTER WHEN THE COLOR BROADCAST WAS RECEIVED IN GOOD CONDITION AND PICTURE IS NORMAL.

NOTE: THIS SCHEMATIC DIAGRAM IS THE LATEST AT THE TIME OF PRINTING AND SUBJECT TO CHANGE WITHOUT NOTICE.

CAUTION: SINCE THESE PARTS MARKED BY \triangle ARE CRITICAL FOR SAFETY, USE ONES DESCRIBED IN PARTS LIST ONLY.

ATTENTION: LES PIECES REPARÉES PAR UN \triangle ETANT DANGEREUSES AN POINT DE VUE SECURITE N'UTILISER QUE CELLS DECRITES DANS LA NOMENCLATURE DES PIECES.

PCB010
VMB289

DEFLECTION SCHEMATIC DIAGRAM (SYSCON PCB)

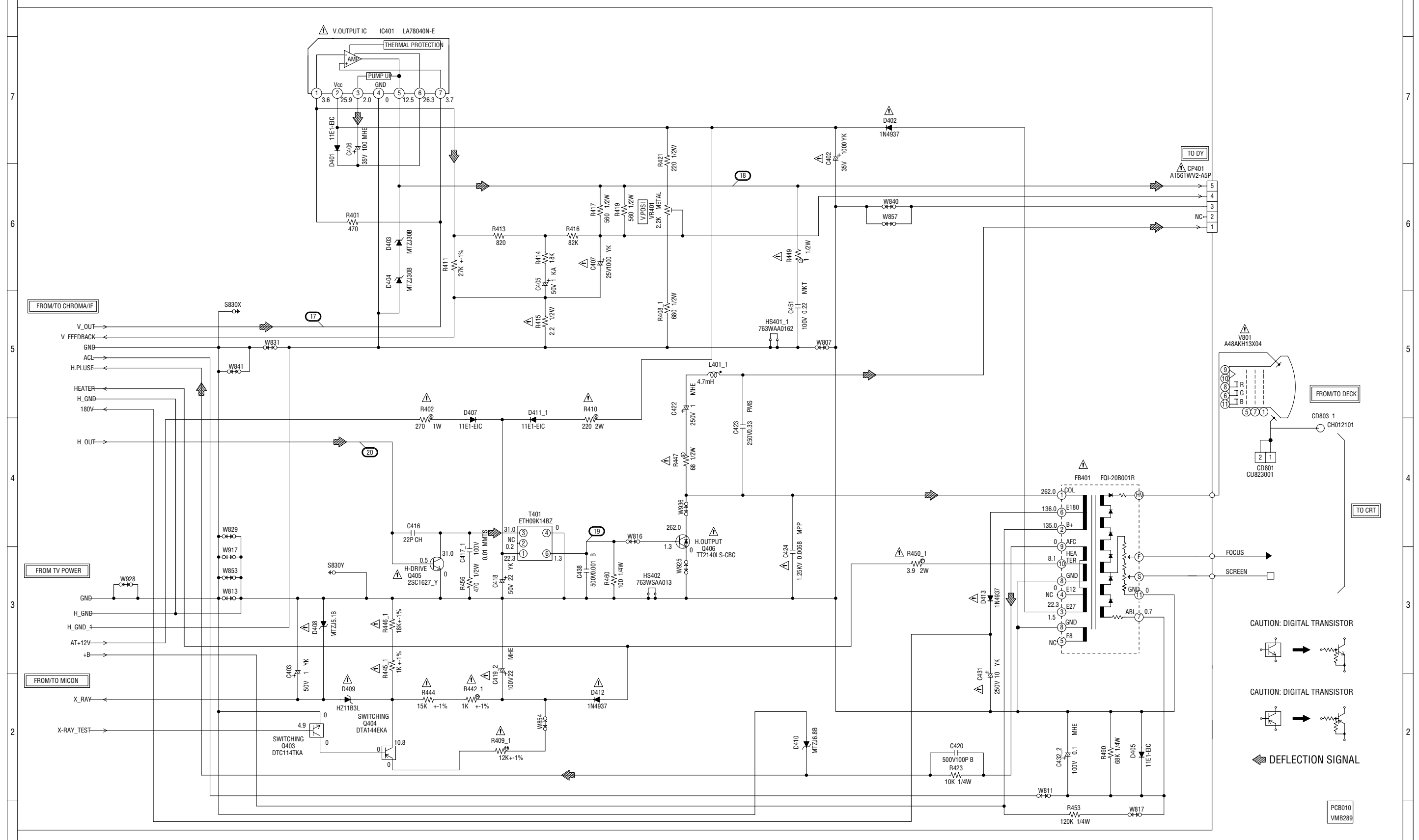

NOTE: THE DC VOLTAGE AT EACH PART WAS MEASURED WITH THE DIGITAL TESTER WHEN THE COLOR BROADCAST WAS RECEIVED IN GOOD CONDITION AND PICTURE IS NORMAL.

NOTE: THIS SCHEMATIC DIAGRAM IS THE LATEST AT THE TIME OF PRINTING AND SUBJECT TO CHANGE WITHOUT NOTICE.

CAUTION SINCE THESE PARTS MARKED WITH ARE CRITICAL FOR SAFETY, USE ONES DESCRIBED IN PARTS LIST ONLY.

NOTE: THE RESISTOR MARKED F IS FUSE RESISTOR. THE ALUMI ELECTROLYTIC CAPACITOR MARKED NP IS NON POLAR ONE.

CAUTION: DIGITAL TRANSISTOR

CAUTION: DIGITAL TRANSISTOR

DEFLECTION SIGNAL

PCB010
VMB289

CRT SCHEMATIC DIAGRAM (CRT PCB)

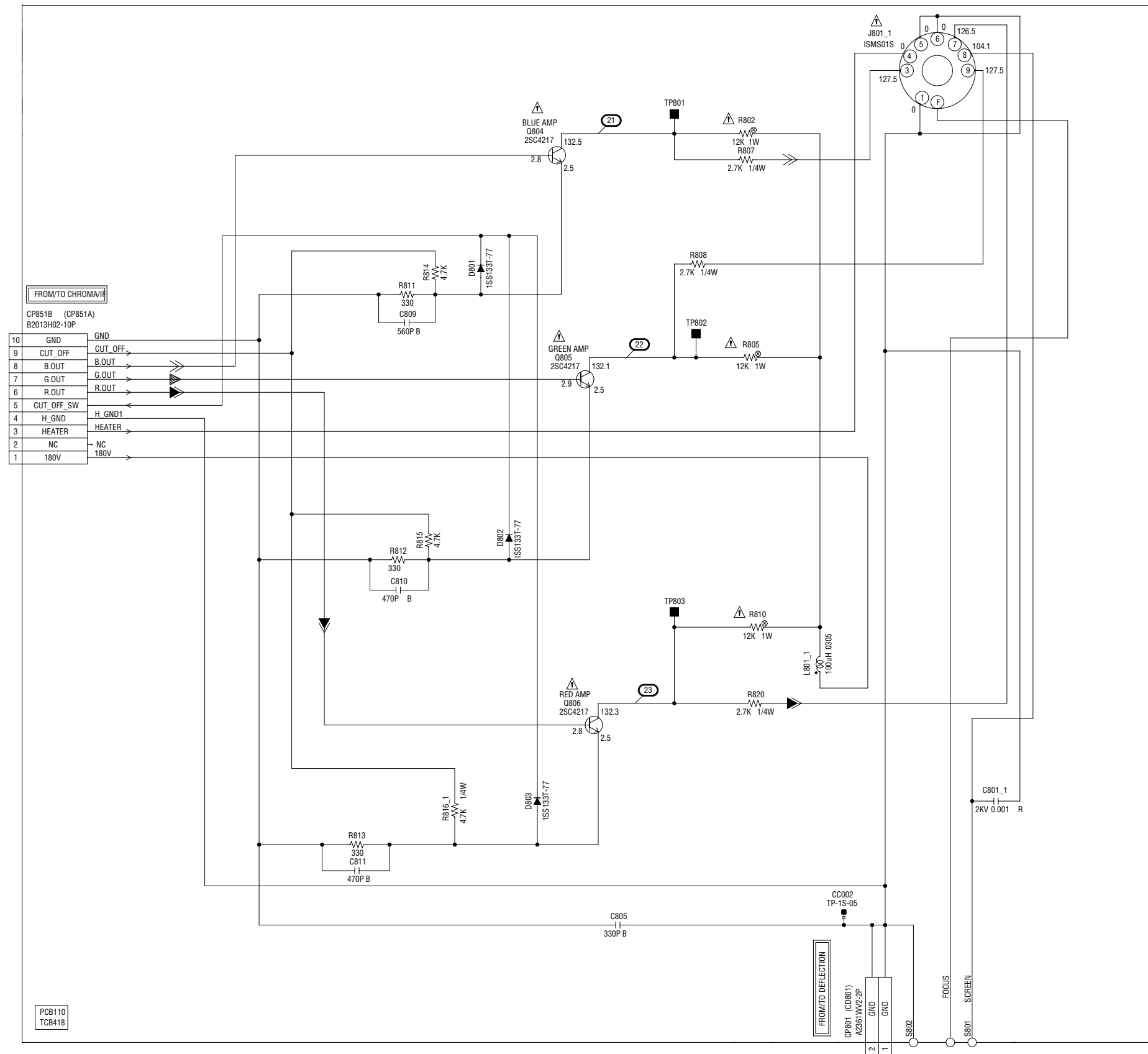

FROM/TO CHROMA/IF

10	GND	CUT_OFF
9	CUT_OFF	B.OUT
8	B.OUT	G.OUT
7	G.OUT	R.OUT
6	R.OUT	H_GND1
5	CUT_OFF_SW	HEATER
4	H_GND	NC
3	HEATER	180V
2	NC	
1	180V	

PCB110
TCB418

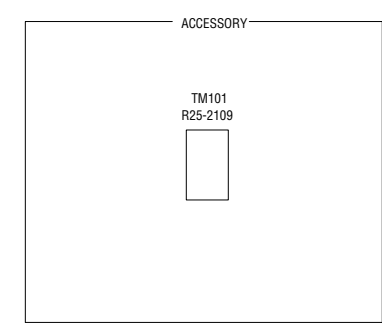

NOTE: THE DC VOLTAGE AT EACH PART WAS MEASURED WITH THE DIGITAL TESTER WHEN THE COLOR BROADCAST WAS RECEIVED IN GOOD CONDITION AND PICTURE IS NORMAL.

NOTE: THIS SCHEMATIC DIAGRAM IS THE LATEST AT THE TIME OF PRINTING AND SUBJECT TO CHANGE WITHOUT NOTICE.

CAUTION SINCE THESE PARTS MARKED BY ARE CRITICAL FOR SAFETY, USE ONES DESCRIBED IN PARTS LIST ONLY.

ATTENTION LES PIÈCES RÉPARÉES PAR UN ÉTANT DANGEREUSES AN POINT DE VUE SÉCURITÉ N'UTILISER QUE CELLES DÉCRITES DANS LA NOMENCLATURE DES PIÈCES.

◀ R.SIGNAL
◀ G.SIGNAL
◀ B.SIGNAL

INTERCONNECTION DIAGRAM (EH8131S)

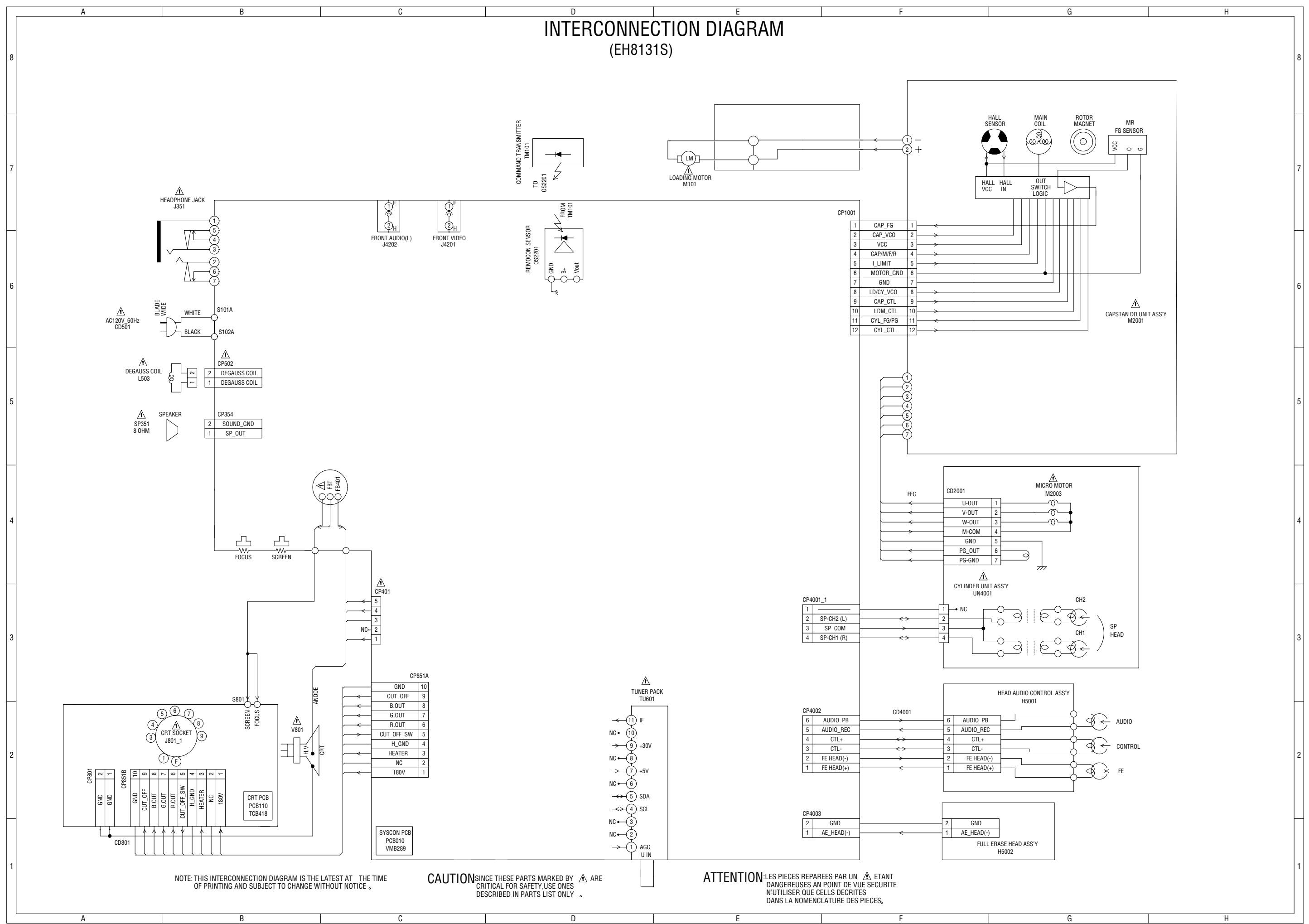

NOTE: THIS INTERCONNECTION DIAGRAM IS THE LATEST AT THE TIME OF PRINTING AND SUBJECT TO CHANGE WITHOUT NOTICE.

CAUTION SINCE THESE PARTS MARKED BY ARE CRITICAL FOR SAFETY, USE ONES DESCRIBED IN PARTS LIST ONLY.

ATTENTION LES PIECES REPARÉES PAR UN ÉTANT DANGEREUSES AU POINT DE VUE SÉCURITÉ N'UTILISER QUE CELLES DÉCRITES DANS LA NOMENCLATURE DES PIÈCES.

WAVEFORMS

Y/C/AUDIO/HEAD AMP

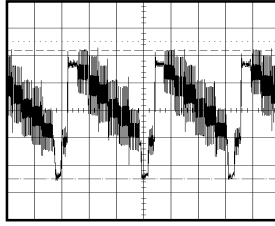

① PB
0.5V 20 μ s/div

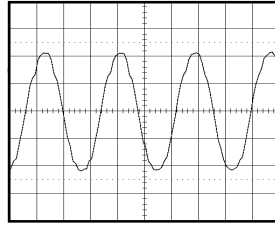

② POWER ON
100mV 0.1 μ s/div

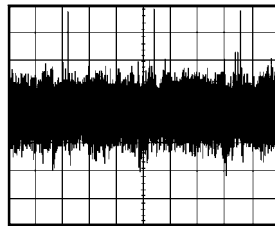

③ PB
10mV 20 μ s/div

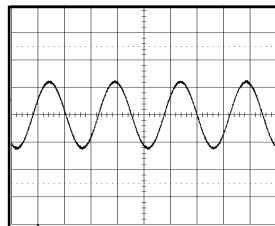

④ PB
0.5V 1ms/div

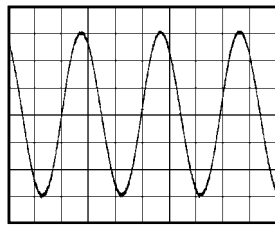

⑤ REC
10.0V 5 μ s/div

MICON

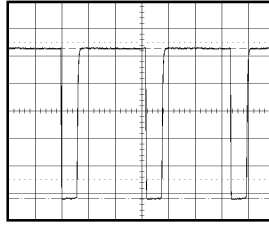

⑥ POWER ON
1.0V 20 μ s/div

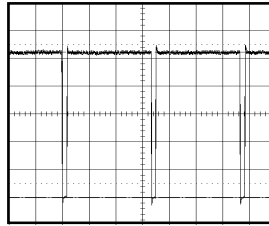

⑦ POWER ON
0.5V 10ms/div

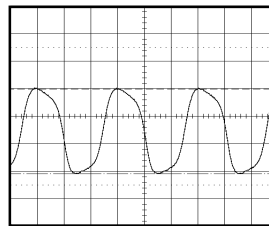

⑧ POWER ON
1.0V 10 μ s/div

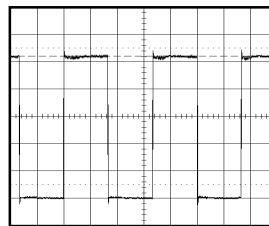

⑨ PB
1.0V 10ms/div

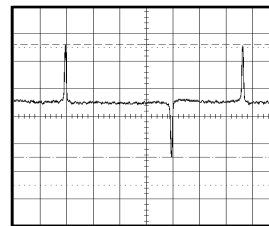

⑩ PB
1.0V 5ms/div

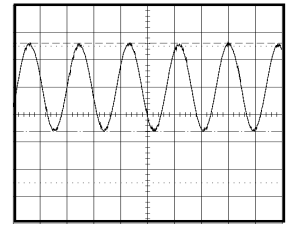

⑪ PB
0.5V 0.5ms/div

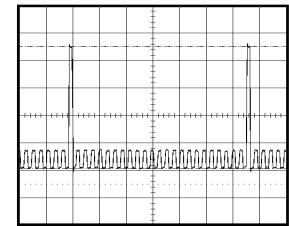

⑬ PB
1.0V 5ms/div

SOUND AMP

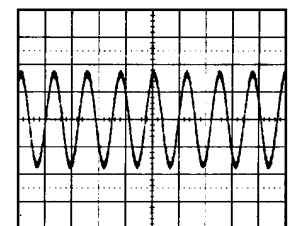

⑭ POWER ON
200mV 2ms/div

DEFLECTION

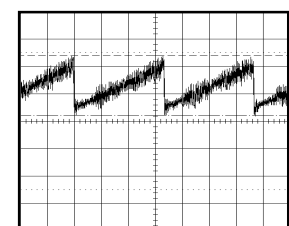

⑰ POWER ON
0.5V 5ms/div

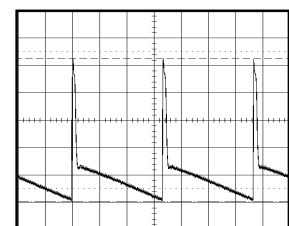

⑱ POWER ON
10.0V 5ms/div

NOTE: The following waveforms were measured at the point of the corresponding balloon number in the schematic diagram.

WAVEFORMS

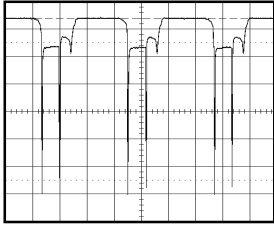

①⑨ POWER ON
2.0V 20 μ s/div

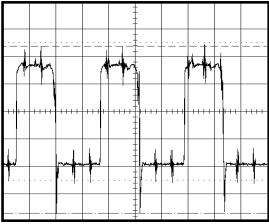

②⑩ POWER ON
200mV 20 μ s/div

CRT

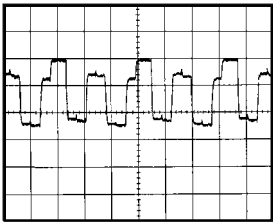

②⑪ POWER ON
50.0V 20 μ s/div

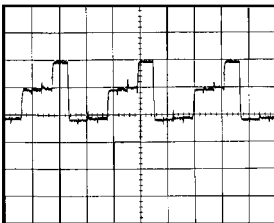

②⑫ POWER ON
50.0V 20 μ s/div

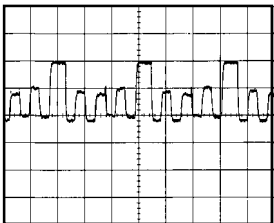

②⑬ POWER ON
50.0V 20 μ s/div

NOTE: The following waveforms were measured at the point of the corresponding balloon number in the schematic diagram.

MECHANICAL EXPLODED VIEW

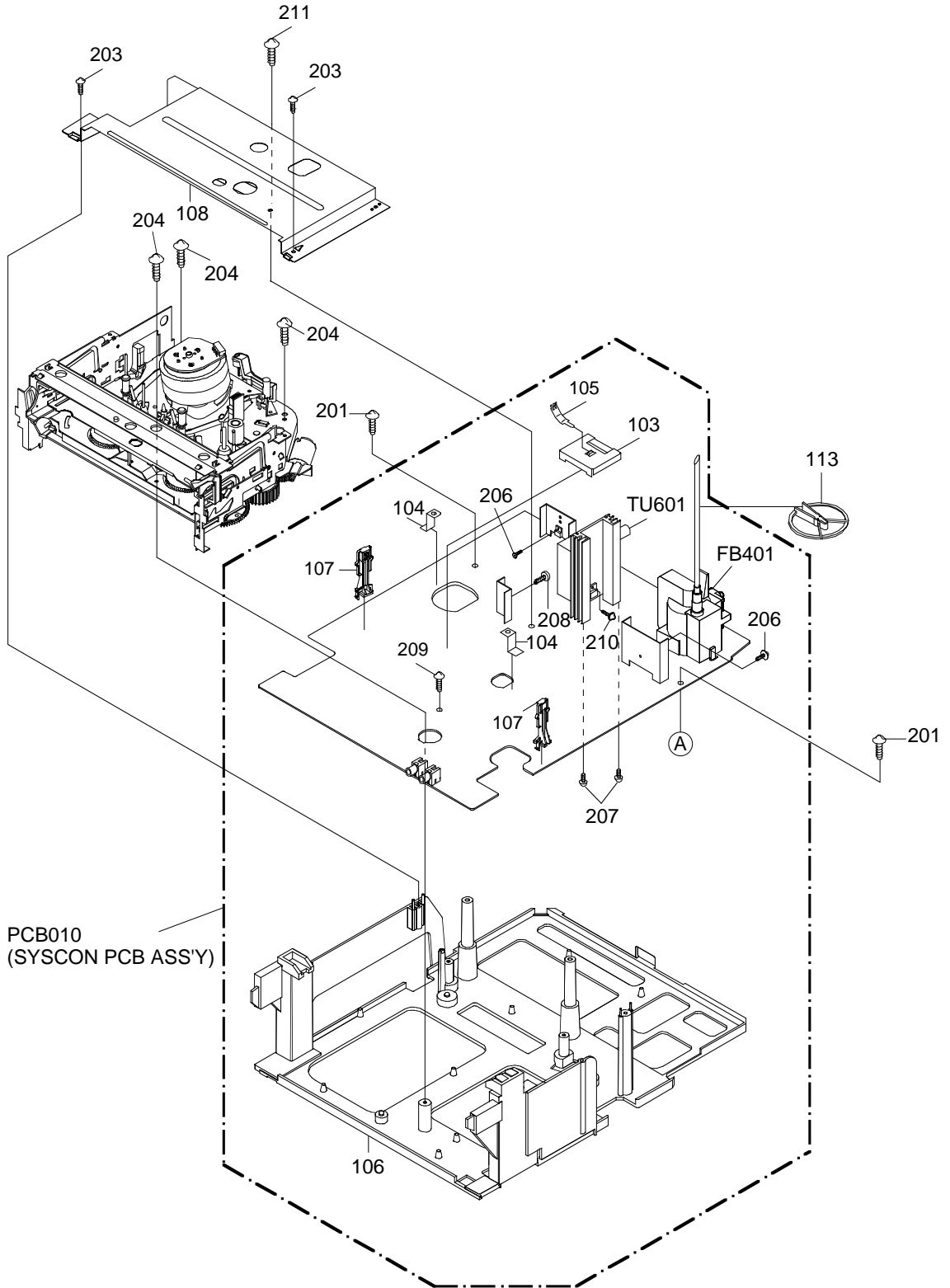

CHASSIS EXPLODED VIEW (BOTTOM VIEW)

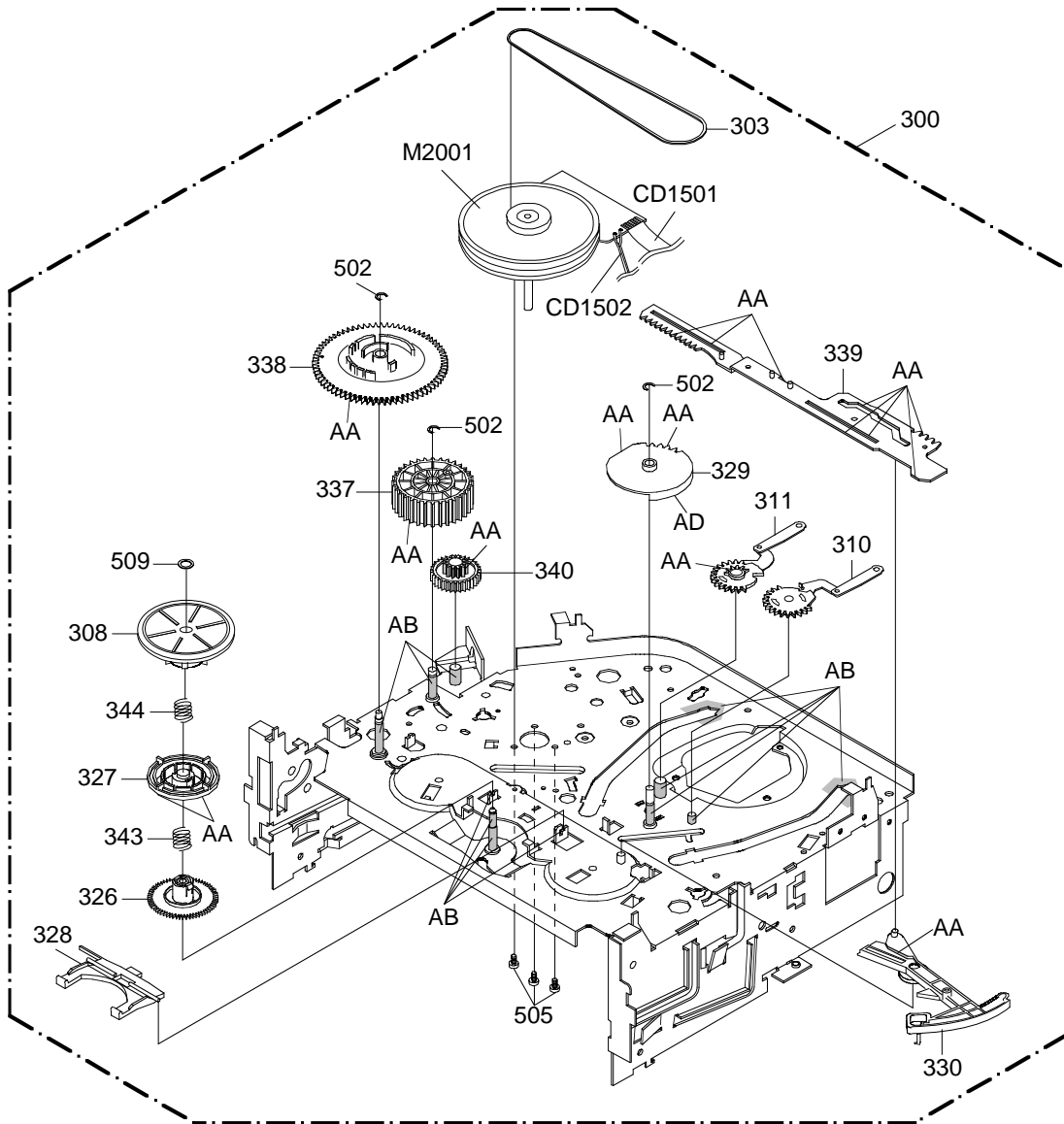

CLASS	PART NO.	PART NAME	MARK
GREASE	Y315061000	G-555G	AA
	Y315071000	MG-33	AB
	Y31D011000	FG-84M	AC
	Y315041000	FL-721	AD
	Y315141000	G-313Y	AE

NOTE: Applying positions AA, AB, AC, AD and AE for the grease are displayed for this section. Check if the correct grease is applied for each position.

MECHANICAL REPLACEMENT PARTS LIST

REF. NO.	PART NO.	DESCRIPTION		
101	7A701A177A	FRONT,CABI ASS'Y		
101A	701WPJC760	CABINET,FRONT		
101B	712WPJC066	FLAT,FLAP		
101C	713WPA0198	GLASS,LED		
101D	713WPA0199	GUIDE,REMOCON		
101E	735WPAA553	BUTTON,BASE		
101F	735WPBB237	BUTTON,FRAME		
101G	743WKA0037	SPRING,FLAP		
101H	800WQ00048	FELT,SHEET	75x75	
102	A5M104Q740	CABINET,BACK ASS'Y		
102A	702WPAA568	CABINET,BACK		
102B	800WQ00041	FELT,SHEET	390x18xT0.5	
103	752WSA0230	SHIELD,CASE HEAD AMP		
104	753WSA0118	PLATE,EARTH-SYSCON		
105	753WUAA006	SPRING,EARTH HEAD AMP		
106	761WPA0225	HOLDER,DECK		
107	85OP700038	HOLDER,END SENSOR		
108	752WSAA051	PLATE,DECK SHIELD		
109	722A08A151	SHEET,RATING		
110	7230006755	SHEET,CAUTION		
111	741WUA0021	SPRING,EARTH		
112	800WR0A002	SHEET,CRT SUPPORT		
113	899HV3T000	HOLDER,ANODE WIRE		
201	8117540B04	SCREW,TAPPING(B0)	TRUSS	4x20
202	8117540A64	SCREW,TAPPING(B0)	TRUSS	4x16
203	8107630604	SCREW,TAP TITE(S)	BRAZIER	3x6
204	8110630A24	SCREW,TAP TITE(P)	BRAZIER	3x12
205	8141J50C54	SCREW,TAP TITE(P)	GW22	5x35
206	8109I30A04	SCREW,TAP TITE(B)	WH7	3x10
207	8109630802	SCREW,TAP TITE(B)	BRAZIER	3x8
208	8109I30804	SCREW,TAP TITE(B)	WH7	3x8
209	8110330804	SCREW,TAP TITE(P)	FLAT	3x8
210	8107630804	SCREW,TAP TITE(S)	BRAZIER	3x8
211	8110E30804	SCREW,TAP TITE(P)	WH10	3X8
212	8110630A04	SCREW,TAP TITE(P)	BRAZIER	3x10
213	8110630804	SCREW,TAP TITE(P)	BRAZIER	3x8
---	791WHA0025	LAMIFILM BAG		
---	792WHA0372	PACKAGE, TOP		
---	792WHA087	PACKAGE,BOTTOM		
---	793WCDC337	GIFT, BOX		
---	A5M104Q975	INSTRUCTION BOOK KIT		
---	J3J81702C	WARRANTY SHEET		
---	J5M10421A	INSTRUCTION BOOK		
---	JA5U0200	POLYBAG,INSTRUCTION		

CHASSIS REPLACEMENT PARTS LIST

REF. NO.	PART NO.	DESCRIPTION	REF. NO.	PART NO.	DESCRIPTION
300	A5E307B420A	DECK ASSY A5E307B420A	501	8107226804	SCREW,TAP TITE(S) BIND 2.6x8
			502	83ETW30000	E-RING 3
301	85OA400234	PINCH ROLLER BLOCK	503	8107226404	SCREW,TAP TITE(S) BIND 2.6x4
	85OA400240	PINCH ROLLER BLOCK (VA)	504	8102120604	SCREW,PAN M2x6
	85OA500026	AHC ASS'Y	505	8109126604	SCREW,TAP TITE(B) PAN 2.6x6
302	85OP200290	BELT,CAPSTAN (S)	506	810A130404	SCREW/WASHER(A) M3x4
303	85OP600581	WORM	507	810A126504	SCREW/WASHER(A) M2.6x5
304	85OP500083	BASE,AC HEAD	508	82Q264713N	POLYSLIDER WASHER 2.6x4.7xT0.13
305	85OP800324	SPRING,AC HEAD	509	82P184505N	POLYSLIDER WASHER(CUT) 1.8x4.5xT0.5
306	85OA000459	MAIN CHASSIS ASS'Y			
307	85OA200089	CLUTCH ASS'Y	510	8107226604	SCREW,TAP TITE(S) BIND 2.6x6
308	85OA200090	ARM IDLER ASS'Y	511	810A123504	SEMS A M2.3x5.0
309					
310	85OA300065	LOADING ARM S UNIT	CD1501	122H071704	CORD JUMPER 2H071704
311	85OA300066	LOADING ARM T UNIT	CD1502	122Y021902	CORD JUMPER 2Y021902
312	85OA400223	INCLINED BASE T UNIT 3S	H5001	1523Q91003	HEAD (AUDIO CONTROL) VTR-1X2RPE22-756
313	85OA400232	P5 ARM ASS'Y 2	H5002	1543Q02014	HEAD (FULL ERASE) VTR-1X2ERS11-154
314	85OA400235	TENSION ARM ASS'Y 2	△ M101	1596P98001	MOTOR (LOADING) MXN13FB12K3 or
315	85OA400231	INCLINED BASE S UNIT		1596S98001	MOTOR (LOADING) MDB2B66
316	85OP800367	SPRING LOCKER	△ M2001	1510S98038	CAPSTAN DD UNIT F2QVB33 or
317	85OP900736	CASS,HOLDER		1510S98040	CAPSTAN DD UNIT F2QVB33B
318	85OP900748	CASS,SIDE L	△ M2003	1589S11014	MICRO MOTOR I2OAL03
319	85OP900749	CASS,SIDE R	△ UN4001	A5A305A500	CYLINDER UNIT ASS'Y A5A305A500
320	85OP900739	LOCKER,R			
321	85OA900228	LINK UNIT			
322	85OP000496	POST,CASS GUIDE			
323	85OP200316	REEL,S (S)			
324	85OP200317	REEL,T (S)			
325	85OP200308	GEAR,IDLER			
326	85OP200311	GEAR,CLUTCH			
327	85OP200312	GEAR,COUPLING			
328	85OP200313	LEVER,CLUTCH			
329	85OP300194	GEAR,MAIN LOADING			
330	85OP400490	LEVER,TENSION			
331	85OP400492	HOLDER,TENSION			
332	85OP400520	CAP,P4			
333	85OP400542	BAND,TENSION			
334	85OP400533	CONNECT,TENSION			
335	85OP600573	ARM,BRAKE T			
336	85OP600584	BAND,BRAKE T			
337	85OP600577	CAM,PINCH ROLLER			
338	85OP600578	CAM,MAIN			
339	85OP600579	ROD,MAIN			
340	85OP600582	GEAR,JOINT			
341	85OP800322	SPRING,TENSION			
342	85OP800360	SPRING,BRAKE T			
343	85OP800355	SPRING,COUPLING			
344	85OP800356	SPRING,RING			
345	85OP900743	LEVER,LINK			
346	85OP900744	LEVER,FLAP			
347	85OP900745	CASS,OPENER			
348	85OP700035	REFLECTOR,LED			
349	85OP900746	BRACKET, TOP 3V			
350	85OP700039	COVER,BOT			

ELECTRICAL REPLACEMENT PARTS LIST

REF. NO.	PART NO.	DESCRIPTION	REF. NO.	PART NO.	DESCRIPTION
RESISTORS			DIODES		
△ R402	R3X181271J	R,METAL OXIDE 270 OHM 1W	△ D530	D2WTRM11C0	DIODE SILICON RM11C-EIC
△ R410	R3X28A221J	R,METAL OXIDE 220 OHM 2W	D533	D1VT001330	DIODE,SILICON 1SS133T-77
△ R415	R002T22R2J	RC 2.2 OHM 1/2W	△ D534	D97U01801B	DIODE,ZENER MTZJ18B T-77
△ R442	R4X5T6102F	R,METAL 1K OHM 1/6W	△ D535	D97U01801B	DIODE,ZENER MTZJ18B T-77
△ R447	R65582680J	R,FUSE 68 OHM 1/2W	D536	D2WXN49370	DIODE,SILICON 1N4937
△ R449	R635U2010J	R,FUSE 1 OHM 1/2W	D537	D1VT001330	DIODE,SILICON 1SS133T-77
△ R450	R6358A3R9J	R,FUSE 3.9 OHM 2W	D601	D1VT001330	DIODE,SILICON 1SS133T-77
△ R500	R0G3K2275K	RC 2.7M OHM 1/2W	D602	D97U08R21B	DIODE,ZENER MTZJ8.2B T-77
△ R501	R5Y2CD3R3J	R,CEMENT 3.3 OHM 5W	D603	D1VT001330	DIODE,SILICON 1SS133T-77
△ R502	R3X28B100J	R,METAL OXIDE 10 OHM 3W	D605	D2WT11ES10	DIODE SILICON 11ES1-EIC
△ R503	R002T2010J	RC 1 OHM 1/2W	D608	D2WXS81400	DIODE SCHOTTKY SB140-EIC
△ R509	R002T2155J	RC 1.5M OHM 1/2W	D609	D97U06R81B	DIODE,ZENER MTZJ6.8B T-77
△ R512	R002T2563J	RC 56K OHM 1/2W	D610	D97U06R81B	DIODE,ZENER MTZJ6.8B T-77
△ R514	R3X181R33J	R,METAL OXIDE 0.33 OHM 1W	D611	D97U06R81B	DIODE,ZENER MTZJ6.8B T-77
△ R517	R3X181331J	R,METAL OXIDE 330 OHM 1W	D801	D1VT001330	DIODE,SILICON 1SS133T-77
△ R528	R63581R22J	R,FUSE 0.22 OHM 1W	D802	D1VT001330	DIODE,SILICON 1SS133T-77
△ R529	R4X5T4272F	R,METAL 2.7K OHM 1/4W	D803	D1VT001330	DIODE,SILICON 1SS133T-77
△ R802	R3X181123J	R,METAL OXIDE 12K OHM 1W	D1001	0010E00330	INFRARED LED LTE-3271T-012A-O
△ R805	R3X181123J	R,METAL OXIDE 12K OHM 1W	D1002	D1VT001330	DIODE,SILICON 1SS133T-77
△ R810	R3X181123J	R,METAL OXIDE 12K OHM 1W	D1004	0021721150	LED SLR-342VCT32
CAPACITORS			D1013	0021721150	LED SLR-342VCT32
C354	E02LF1222M	CE 2200 UF 10V	D1014	D97U06R81B	DIODE,ZENER MTZJ6.8B T-77
△ C402	E02LF4102M	CE 1000 UF 35V	D2201	D97U06R81B	DIODE,ZENER MTZJ6.8B T-77
△ C407	E02LF3102M	CE 1000 UF 25V	D4001	D97U01301B	DIODE,ZENER MTZJ13B T-77
△ C419	E5EZT8220M	CE 22 UF 100V	D4002	D97U01301B	DIODE,ZENER MTZJ13B T-77
C423	P4J7F3334J	CMPP 0.33 UF 250V PMS	ICS		
△ C424	P4N8FJ682H	CMPP 0.0068UF 1.25KV	△ IC351	I01DP75110	IC AN7511
△ C431	E02LTD100M	CE 10 UF 250V	△ IC401	I03TD804N0	IC LA78040N-E
△ C506	P2122B224M	CMP 0.22 UF 275V ECQUL	△ IC501	I1KA9R05A0	IC KIA78R05API
△ C507	C0JTB0513K	CC 0.001 UF 500V B	△ IC502	0002500450	PHOTO COUPLER TLP621(GR)
△ C508	C0JTB0513K	CC 0.001 UF 500V B	IC601	I06FC61250	IC M61250FP
C509	E51CGC331M	CE 330 UF 200V	IC1001	I56F57107A	IC OEC7107A
	E52DGC331M	CE 330 UF 200V	IC1003	IE2F031020	IC XC61CN3102SR or
△ C511	E02LT3471M	CE 470 UF 25V		I9UF032310	IC PST3231NR
△ C516	C0JTB05Q2K	CC 470 PF 500V B	IC1099	A5M104Q015	INIT DATA or
C517	C0PLRR7Q2K	CC 470 PF 2KV R	IC4001	I03F3206M0	IC LA71206M-MPB or
	C03L0R7Q2K	CC 470 PF 2KV R	TRANSISTORS		
△ C521	E62NFC221M	CE 220 UF 200V	Q403	TNYJJ05001	COMPOUND TRANSISTOR DTC114TKAT146 or
△ C522	E02LU5010M	CE 1 UF 50V		TNAAJ05003	COMPOUND TRANSISTOR KRC111SRTK
C523	E02LF2332M	CE 3300 UF 16V	Q404	TPYJD05001	COMPOUND TRANSISTOR DTA144EKAT146 or
C524	E02LF1222M	CE 2200 UF 10V		TPAAD05003	COMPOUND TRANSISTOR KRA104SRTK
△ C530	CD39E0M13M	CC 0.001 UF 250V	△ Q405	TC5T01627Y	TRANSISTOR SILICON 2SC1627_Y(TPE2)
C535	C0PLRR713K	CC 0.001 UF 2KV R	△ Q406	TD3U021400	TRANSISTOR SILICON TT2140LS-CBC
△ C539	CD39E0ML3M	CC 0.0033UF 250V	Q505	T6YJ1037K0	TRANSISTOR,SILICON 2SA1037AKT146R,S
C541	C0PLRR7G3K	CC 0.0018 UF 2KV R	Q507	TCATC31980	TRANSISTOR,SILICON KTC3198-AT(Y,GR)
C801	C0PLRR713K	CC 0.001 UF 2KV R	△ Q510	T25F035630	FET 2SK3563(ORION_Q)
DIODES			△ Q511	TCAT032034	TRANSISTOR, SILICON KTC3203_Y-AT
D401	D2WT011E10	DIODE SILICON 11E1-EIC	Q601	T6YJ1037K0	TRANSISTOR,SILICON 2SA1037AKT146R,S
△ D402	D2WXN49370	DIODE SILICON 1N4937	Q602	TCAT032034	TRANSISTOR, SILICON KTC3203_Y-AT
D403	D97U03001B	DIODE,ZENER MTZJ30B T-77	Q603	TCAT032034	TRANSISTOR, SILICON KTC3203_Y-AT
D404	D97U03001B	DIODE,ZENER MTZJ30B T-77	Q604	TDAT00863Y	TRANSISTOR SILICON KTD863_Y-AT
D405	D2WT011E10	DIODE SILICON 11E1-EIC	Q605	TDAT00863Y	TRANSISTOR SILICON KTD863_Y-AT
D407	D2WT011E10	DIODE SILICON 11E1-EIC	Q606	TCAT032034	TRANSISTOR, SILICON KTC3203_Y-AT
△ D408	D97U05R11B	DIODE,ZENER MTZJ5.1B T-77	Q607	T8YJ2412K0	TRANSISTOR SILICON 2SC2412KT146 R,S
△ D409	D94TA11B13	DIODE ZENER HZ11B3L TD	Q609	TNYJB05001	COMPOUND TRANSISTOR DTC114EKAT146 or
D410	D97U06R81B	DIODE,ZENER MTZJ6.8B T-77		TNAAB05003	COMPOUND TRANSISTOR KRC102SRTK
D411	D2WT011E10	DIODE SILICON 11E1-EIC	Q611	TPYJB05001	COMPOUND TRANSISTOR DTA114EKAT146 or
△ D412	D2WXN49370	DIODE SILICON 1N4937		TPAAB05001	COMPOUND TRANSISTOR KRA102SRTK
△ D413	D2WXN49370	DIODE SILICON 1N4937	Q612	TNYJB05001	COMPOUND TRANSISTOR DTC114EKAT146
D501	D97U01001B	DIODE,ZENER MTZJ10B T-77	△ Q804	TC3F042170	TRANSISTOR,SILICON 2SC4217(D,E)-RAC or
D502	D1VT001330	DIODE,SILICON 1SS133T-77		TCA0042170	TRANSISTOR SILICON KTC4217(O,Y)
D503	D97U08R21B	DIODE,ZENER MTZJ8.2B T-77	△ Q805	TC3F042170	TRANSISTOR,SILICON 2SC4217(D,E)-RAC or
D504	D1VT001330	DIODE,SILICON 1SS133T-77		TCA0042170	TRANSISTOR SILICON KTC4217(O,Y)
△ D505	D28T21DQN9	DIODE SCHOTTKY 21DQ09N-TA2B1	△ Q806	TC3F042170	TRANSISTOR,SILICON 2SC4217(D,E)-RAC or
△ D507	D28T21DQN9	DIODE SCHOTTKY 21DQ09N-TA2B1		TCA0042170	TRANSISTOR SILICON KTC4217(O,Y)
D508	D1VT001330	DIODE,SILICON 1SS133T-77	Q1003	0002700680	PHOTO COUPLER RPI-352C40N
△ D510	D2WXR02AM0	DIODE SILICON RU2AM-EIC	Q1004	TNYJC05001	COMPOUND TRANSISTOR DTC124EKAT146 or
△ D512	D28T21DQN9	DIODE SCHOTTKY 21DQ09N-TA2B1		TNAAC05002	COMPOUND TRANSISTOR KRC103SRTK
D513	D1VT001330	DIODE,SILICON 1SS133T-77	Q1005	0002700690	PHOTO COUPLER RPI-303
D514	D1VT001330	DIODE,SILICON 1SS133T-77	Q1007	TNYJB05001	COMPOUND TRANSISTOR DTC114EKAT146 or
△ D515	D97U03301B	DIODE,ZENER MTZJ33B T-77		TNAAB05003	COMPOUND TRANSISTOR KRC102SRTK
△ D517	D2WXN49370	DIODE SILICON 1N4937	Q1009	0002700680	PHOTO COUPLER RPI-352C40N
△ D518	D2WTRM11C0	DIODE SILICON RM11C-EIC	Q1011	0000M00390	PHOTO TRANSISTOR ST-304L
△ D519	D28T21DQN9	DIODE SCHOTTKY 21DQ09N-TA2B1	Q1013	0000M00390	PHOTO TRANSISTOR ST-304L
△ D520	D2WTRM11C0	DIODE SILICON RM11C-EIC	Q1014	TNYJC05001	COMPOUND TRANSISTOR DTC124EKAT146 or
△ D521	D2WTRM11C0	DIODE SILICON RM11C-EIC		TNAAC05002	COMPOUND TRANSISTOR KRC103SRTK
D528	D97U05R61B	DIODE,ZENER MTZJ5.6B T-77	Q4001	TCATC31980	TRANSISTOR,SILICON KTC3198-AT(Y,GR)

ELECTRICAL REPLACEMENT PARTS LIST

REF. NO.	PART NO.	DESCRIPTION	REF. NO.	PART NO.	DESCRIPTION		
TRANSISTORS			MISCELLANEOUS				
Q4001	TCATC31980	TRANSISTOR,SILICON	KTC3198-AT(Y,GR)	CP505	069D01001A	CONNECTOR PCB SIDE	003P-2100
Q4002	TCATC31980	TRANSISTOR,SILICON	KTC3198-AT(Y,GR)	CP801	069S320010	CONNECTOR PCB SIDE	A2361WV2-2P
Q4003	TPYJC05001	COMPOUND TRANSISTOR	DTA124EKAT146	CD4001	122F061502	CORD JUMPER	2F061502
	TPAAC05002	COMPOUND TRANSISTOR	KRA103SRTK	CP1001	06972C0010	CONNECTOR PCB SIDE	TMC-J12P-B2
Q4005	TAATA12660	TRANSISTOR,SILICON	KTA1266-AT(Y,GR)	CP1003	0694240139	CONNECTOR PCB SIDE	173979-4
Q4006	TCAT032034	TRANSISTOR, SILICON	KTC3203_Y-AT	CP4001	0697240600	CONNECTOR PCB SIDE	TOC-C04X-B1
Q4007	T8YJ2412K0	TRANSISTOR SILICON	2SC2412KT146 R,S	CP4002	069J760029	CONNECTOR PCB SIDE	IMS-A-9604S-06Z14
Q4009	T6YJ1037K0	TRANSISTOR,SILICON	2SA1037AKT146R,S	CP4003	067U002019	WIRE HOLDER	B2013H02-2P
Q4010	T6YJ1037K0	TRANSISTOR,SILICON	2SA1037AKT146R,S	CP851A	067U010049	WIRE HOLDER	B2013H02-10P
Q4011	T8YJ2412K0	TRANSISTOR SILICON	2SC2412KT146 R,S	CP851B	067U010049	WIRE HOLDER	B2013H02-10P
Q4012	T8YJ2412K0	TRANSISTOR SILICON	2SC2412KT146 R,S	CUS013	800WFAA008	CUSHION C	
Q4202	TNYJB05001	COMPOUND TRANSISTOR	DTC114EKAT146	△ F501	081PC05005	FUSE	51MS050L
	TNAAB05003	COMPOUND TRANSISTOR	KRC102SRTK	△ F502	081PC2R505	FUSE	51MS025L
COILS & TRANSFORMERS							
L401	021L75472J	COIL	4.7 MH	△ FB401	043219014F	TRANSFORMER,FLYBACK	FQI-20B001R
△ L502	029X000087	COIL,LINE FILTER	SS24V-10100	FH501	06710T0009	HOLDER,FUSE	EYF-52BCY
△ L503	028R200029	COIL,DEGAUSS	8R200029	FH502	06710T0009	HOLDER,FUSE	EYF-52BCY
L601	021LA6R56M	COIL	0.56 UH	FH503	06710T0009	HOLDER,FUSE	EYF-52BCY
L603	02167F470J	COIL	47 UH	FH504	06710T0009	HOLDER,FUSE	EYF-52BCY
L607	0216A6120K	COIL	12 UH	OS2201	077Q004017	REMOTE RECEIVER	PIC-37243SR
L609	02167F101J	COIL	100 UH	△ SP351	070C133017	SPEAKER	SG08G35BRA
L616	021LA6R39M	COIL	0.39 UH	△ TH501	DF5EL3R0A0	DEGAUSS ELEMENT	ZPB45BL3R0A
L801	02167F101J	COIL	100 UH	TM101	076R0JE02A	TRANSMITTER	R25-2109
L1001	0216A62R2K	COIL	2.2 UH	△ TU601	0145K00062	TUNER,VHF-UHF	TECC1040PG38W
L4001	02167F220J	COIL	22 UH	△ V801	098Q200490	CRT W/DY	A48AKH13X04
L4003	02167F101J	COIL	100 UH	X602	100DT3R531	CRYSTAL	HC-49/U
L4005	02167F470J	COIL	47 UH	X1001	100CT01207	CRYSTAL	HC-49/U-S
L4006	02167F470J	COIL	47 UH	X1002	100DA32R01	CRYSTAL	DT-26
L4009	02167F101J	COIL	100 UH	X4001	100CT3R502	CRYSTAL	HC-49/U
T401	045009003J	TRANS.HORIZONTAL DRIVE	ETH09K14BZ	RESISTOR			
△ T501	0481290804	TRANSFORMER,SWITCHING	81290804	RC.....	CARBON RESISTOR		
T4001	031626009R	COIL,BIAS OSC	1626009	CAPACITORS			
JACKS							
△ J351	060J131016	HEADPHONE JACK	MSJ-2000_AG	CC.....	CERAMIC CAPACITOR		
△ J801	066F120018	SOCKET,CATHODE RAY TUBE	ISMS01S	CE.....	ALUMI ELECTROLYTIC CAPACITOR		
J4201	060Q401077	RCA JACK	AV1-09D-3	CP.....	POLYESTER CAPACITOR		
J4202	060Q401076	RCA JACK	AV1-09D-4	CPP.....	POLYPROPYLENE CAPACITOR		
SWITCHES							
SW1001	0508S11001	SWITCH (LEAF)	LSA-1144EAU	CPL.....	PLASTIC CAPACITOR		
SW2201	0504101T34	SWITCH,TACT	EVQ21505R	CMP.....	METAL POLYESTER CAPACITOR		
SW2202	0504101T34	SWITCH,TACT	EVQ21505R	CMPL.....	METAL PLASTIC CAPACITOR		
SW2203	0504101T34	SWITCH,TACT	EVQ21505R	CMPP.....	METAL POLYPROPYLENE CAPACITOR		
SW2204	0504101T34	SWITCH,TACT	EVQ21505R				
SW2205	0504101T34	SWITCH,TACT	EVQ21505R				
SW2206	0504101T34	SWITCH,TACT	EVQ21505R				
SW2207	0504101T34	SWITCH,TACT	EVQ21505R				
SW2208	0504101T34	SWITCH,TACT	EVQ21505R				
SW2209	0504101T34	SWITCH,TACT	EVQ21505R				
SW2210	0504101T34	SWITCH,TACT	EVQ21505R				
VARIABLE RESISTORS							
VR401	V1K63H3BTE	VOLUME,SEMI FIXED	NVG6TLTAB222				
VR502	V1163L2BTC	VOLUME,SEMI FIXED	EVNCYAA03BY2				
P.C.BOARD ASSEMBLIES							
PCB010	A5M104Q010	PCB ASS'Y	VMB289B				
PCB110	A5M101Q110	PCB ASS'Y	TCB418B				
MISCELLANEOUS							
B501	024HT03563	CORE,BEADS	W4BRH3.5X6X1.0X2				
B503	024HT03553	CORE,BEADS	W5RH3.5X5X1.0				
B505	024HT03553	CORE,BEADS	W5RH3.5X5X1.0				
B602	024HT03553	CORE,BEADS	W5RH3.5X5X1.0				
△ CD501	1209414909	CORD AC BUSH	9414909			or	
	120R414903	CORD AC BUSH	0R414903			or	
	1207414911	CORD AC BUSH	7414911				
CD801	06CU823001	CORD CONNECTOR	CU823001				
CD851	WHL6042038	FLAT CABLE AWM2468	AWG26 10C BLACK 420MM				
CD852	06CH01408A	CORD EIS CONNECTOR	CH01408A				
CD853	06CH012101	CORD CONNECTOR	CH012101				
CF601	1029045R7G	FILTER,SAW	TSF5229P3				
CF602	1012T04702	FILTER,CERAMIC TRAP	MKT47.3MC110P-TF				
CF603	1012T4R520	FILTER,CERAMIC	SFSRA4M50CF00-A0				
CF604	1012T4R519	FILTER,CERAMIC TRAP	TPSRA4M50C00-A0				
CP351	069E260659	CONNECTOR PCB SIDE	00_8283_0611_00_00				
CP354	06CU123201	CORD CONNECTOR	CU123201				
CP401	069S450089	CONNECTOR PCB SIDE	A1561WV2-A5P				
△ CP502	069S420110	CONNECTOR PCB SIDE	A1561WV2-2P			or	
	069S420099	CONNECTOR PCB SIDE	A1561WV2-2PK				
CP504	069D01001A	CONNECTOR PCB SIDE	003P-2100				

SPEC.NO.	M5M1-04Q
O/R NO.	W465004